

SG Series Sprinkler Gauge

For Fire Protection Service

SPRINKLER

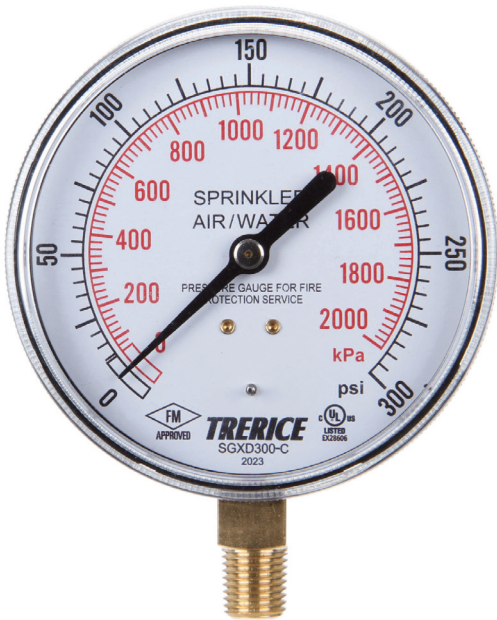

SGXD300-C Shown



- ▶ 3 1/2" Dial Size
- ▶ ±3-2-3% Accuracy
- ▶ Plastic Case
- ▶ Zero zone on dial
- ▶ Single, Dual Scale & Private-labeling
- ▶ UL-listed (UL-393) US & Canada
- ▶ FM Approved (Approval Standard 2311)

The **SG Series Sprinkler Gauge** is specifically designed for the demanding pressure measurement requirements of the fire protection industry. The SG Series is furnished with a polycarbonate case & window. Wetted parts are a bronze tube with a brass socket. Single scale, dual scale and private labeling is available. This gauge is UL-listed (UL-393), US & Canada and is FM Approved (Approval Standard 2311) for fire protection system service.

- For correct use and application of all pressure gauges, please refer to: Pressure Gauge Standard ASME B40.100.

Specifications

Models	SGX (air/water) SGR (air)
Dial Size	3 1/2"
Wetted Parts	Bronze tube, brass socket
Movement	Brass
Connection	Lower male, 1/4 NPT
Case	Black Polycarbonate, stem-mounted flangeless
Window	Polycarbonate, threaded
Pointer	Plain, black finished
Dial Face	Aluminum, white background with black and red graduations and markings
Accuracy	±3-2-3% ASME B40.100 Grade B
Options	Private label / OEM dial
Maximum Temperature	150°F (65° C)
Approximate Shipping Weight	0.4 lbs [0.18 kg]
Approvals	UL-listed (UL-393) US & Canada FM Approved (Approval Standard 2311)

Standard Model

Part Number	Service	Specific Range
SGXD300-C	Air / Water	0 to 300 psi / 0 to 2000 kPa

Other Available Models

SGXA300 SGXD300*	Water	0 to 300 psi 0 to 300 psi / 0 to 2000 kPa
SGRA80/250 SGRD80/250*	Air	0 to 80 psi (250 psi retard) 0 to 80 psi (250 psi retard) / 0 to 550 kPa (1720 kPa retard)

* psi inner scale / kPa outer scale

All dimensions are nominal. Dimensions in [] are in millimeters.

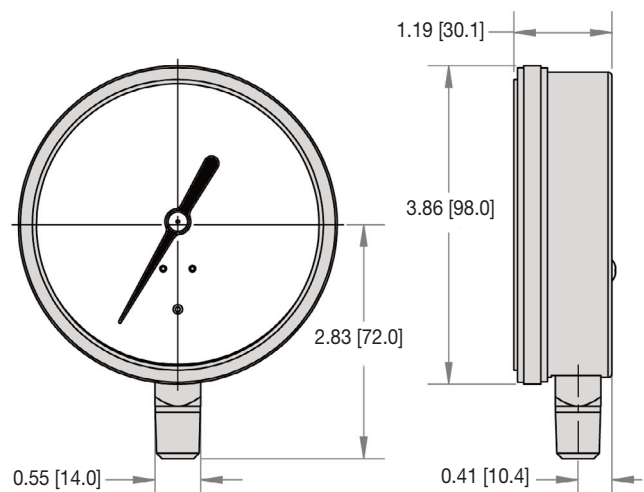

SG Series Sprinkler Gauge Kit

For Fire Protection Service

SPRINKLER



The "Sprinkler Gauge Kit" includes all the necessary hardware to properly mount the included pressure gauge at a variety of locations, including check valves, control valves and main-drains.

Item No.	Description	Approx Shipping Weight
SGXD300-CKIT	Sprinkler Gauge Kit	1.2 lbs [0.54 kg]

SGXD300-CKIT Contains the following:

- Sprinkler Gauge, Air-Water, 300 psi, UL/ULc/FM
- 4" Nipple IPS 1/4
- 1/2 X 1/4 Bushing
- 1/4 Plug
- 3-Way Brass valve 1/4