

# D87 Series

Tube Stub Connection • Liquid Filled or Dry • Stainless Steel Case

INDUSTRIAL GAUGES



D87LFSS shown

- ▶ Provides 360° gauge orientation for easier viewing
- ▶ Eliminates the need for PTFE tape or other sealants
- ▶ ±1.6% Accuracy
- ▶ Stainless Steel Case
- ▶ Glycerine Fill Standard

The Trerice **D87 Series** Industrial Gauge is provided with a Tube Stub connection which allows for 360° orientation of the gauge for better viewing and also eliminates the need for PTFE tape or other sealing materials. All welded design through to the bourdon tube insures robust construction and eliminates potential leakage due to mechanical connections. Available connection sizes include 1/4" and 3/8". In addition the D87 Series features a rugged stainless steel case and crimped ring. Wetted parts are also stainless steel. The gauge comes standard glycerin filled to help reduce pointer flutter and lubricate the movement. For higher temperature applications a dry version (model D87SS) is available.

- Optional features and case style variations available: Please consult the Options & Accessories Section for details.
- For correct use and application of all pressure gauges, please refer to: Pressure Gauge Standard ASME B40.100.

**Note: "NEW" Range Codes**

## HOW TO ORDER

Sample Order Number: **D87LFSS 25 02TS L A 300**

Model	Dial Size	Connection Size	Connection Location	Units of Measure	Range Code
D87LFSS D87SS	25 2 1/2"	02TS 1/4" Tube-Stub 03TS 3/8" Tube-Stub	L Lower B Back	A psi D psi/kPa	See Standard Ranges  Note: "NEW" Range Codes

## Specifications

Models	Wetted Parts	
D87LFSS D87SS	(liquid filled) (dry)	316 Stainless steel, tube & socket
Dial Size	2 1/2"	
Fill	Glycerine, other fills available See Optional Features Section	
Movement	316 Stainless steel	
Connection	1/4" or 3/8" Tube Stub, lower or center back mount	
Case	304 stainless steel, stem-mounted flangeless	
Ring	Crimped 304 stainless steel	
Window	Acrylic	
Pointer	Plain, black finished	
Dial Face	Aluminum, white background with black graduations and markings	
Accuracy	±1.6% Full Scale	
Maximum Temperature	150°F (65°C)	
Approximate Shipping Weight	0.5 lbs [0.23 kg]	



# D87 Series

## Tube Stub Connection • Liquid Filled or Dry • Stainless Steel Case

INDUSTRIAL GAUGES

All dimensions are nominal. Dimensions in [ ] are in millimeters.

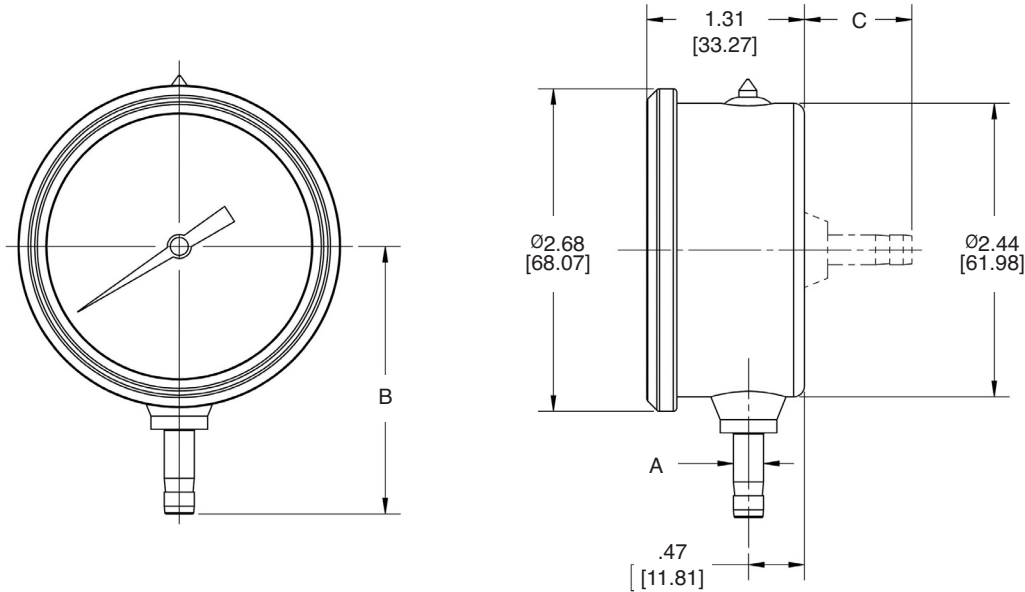

TUBE STUB SIZE	A	B	C
1/4"	.250" [6.35]	2.22" [56.39]	.92" [23.37]
3/8"	.375" [9.53]	2.33" [59.18]	1.08" [27.43]

### Standard Ranges

Note: "NEW" Range Codes

psi Ranges (A)				
NEW Range Code	OLD Range Code	Specific Range	Figure Intervals	Minor Divisions
30/0	010	30" Hg to 0	5	0.5
30/15	020	30" Hg to 15 psi	10/5	1/0.5
30/30	030	30" Hg to 30 psi	10/5	1/1
30/60	040	30" Hg to 60 psi	10/10	2/1
30/100	050	30" Hg to 100 psi	30/20	2/2
30/150	060	30" Hg to 150 psi	30/30	5/2
30/300	070	30" Hg to 300 psi	30/50	5/5
30/400	075	30" Hg to 400 psi	30/50	10/5
15	080	0 to 15 psi	3	0.2
30	090	0 to 30 psi	5	0.5
60	100	0 to 60 psi	10	1
100	110	0 to 100 psi	10	1

psi Ranges (A)				
NEW Range Code	OLD Range Code	Specific Range	Figure Intervals	Minor Divisions
160	120	0 to 160 psi	20	2
200	130	0 to 200 psi	20	2
300	140	0 to 300 psi	50	5
400	150	0 to 400 psi	50	5
600	160	0 to 600 psi	100	10
1000	180	0 to 1000 psi	100	20
1500	190	0 to 1500 psi	300	20
2000	200	0 to 2000 psi	200	20
3000	210	0 to 3000 psi	500	50
5000	220	0 to 5000 psi	1000	100
6000	222	0 to 6000 psi	1000	100

For dual scale ranges specify the appropriate **Units of Measure:**  
D (psi/kPa) followed by the corresponding A (psi) Range Code

