

# Rigid Stem

7" • 9" • 12" Scale Sizes

INDUSTRIAL THERMOMETERS



BX12403 shown

- ▶ 7", 9", 12" Scale
- ▶ ± 1 Scale Division Accuracy
- ▶ Cast Aluminum Case
- ▶ Rigid Straight or Rigid 90° Angle Case

The **Rigid Stem Industrial Thermometer** is offered for applications where a nonadjustable case is preferred. The durable cast aluminum case is available in rigid straight or rigid 90° angle forms. This thermometer features accuracy, responsiveness and durability.

- Optional features available: Please consult the Options & Accessories Section for details.

#### Thermowell

- For applications where the process media may be corrosive or contained under pressure, the use of a thermowell is required to prevent damage to the thermometer and facilitate its removal from the process. (Refer to page 152)

## Specifications

Models	Scale Sizes	
AX1	7"	] Rigid Straight
BX1	9"	
CX1	12"	
AX2	7"	] Rigid 90° Angle
BX2	9"	
CX2	12"	
<b>Fill Type</b>	Spirit: Blue colored, organic	
<b>Case</b>	Cast Aluminum, blue epoxy finish	
<b>Stem</b>	Aluminum, brass, 304 stainless steel	
<b>Connection</b>	11/4-18 UNEF-2A coupling nut	
<b>Window</b>	Acrylic on ranges to 300° F Glass on ranges over 300° F	
<b>Tube</b>	Lens front, magnifying type	
<b>Scale</b>	Aluminum, white background with black graduations and markings	
<b>Top Plate</b>	ABS	
<b>Accuracy</b>	±1 scale division	
<b>Approximate Shipping Weight</b>		
	AX1: 1.2 lbs [0.55 kg]	
	BX1: 1.4 lbs [0.64 kg]	
	CX1: 1.8 lbs [0.82 kg]	
	AX2: 1.0 lbs [0.45 kg]	
	BX2: 1.3 lbs [0.59 kg]	
	CX2: 1.7 lbs [0.77 kg]	

## HOW TO ORDER

Sample Order Number: **CX1 2 406 15**

Model	Stem (Material)	Stem (Length)	Specific Range
AX1 7" ]	1 Aluminum	403 3 1/2"	See Standard Ranges
BX1 9" ]			
CX1 12" ]			
AX2 7" ]	2 Brass	406 6"	
BX2 9" ]			
CX2 12" ]			
	3 304 SS	408 8"	
			512 12"

# Rigid Stem

All dimensions are nominal.  
Dimensions in [ ] are in millimeters.

## Rigid-Straight

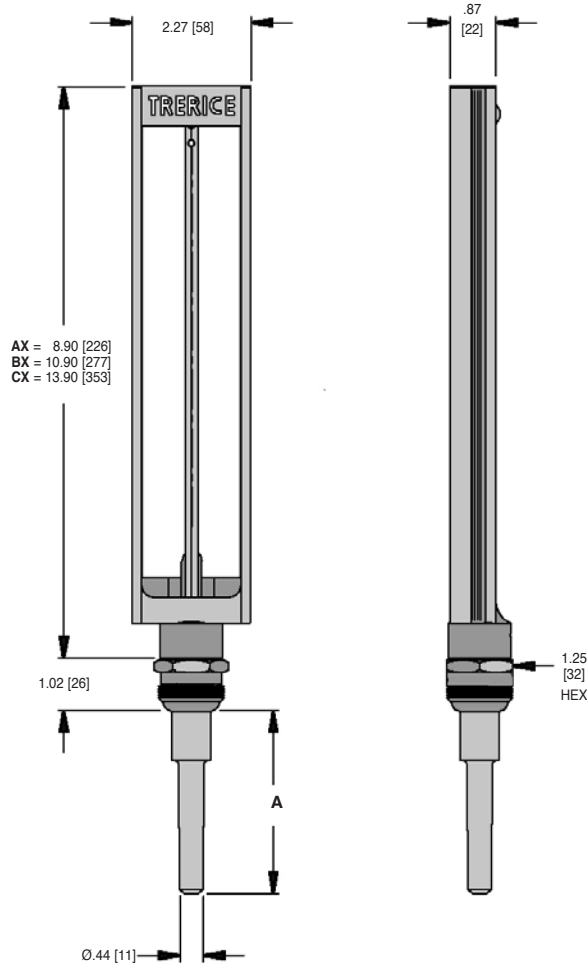

## Rigid-90° Angle

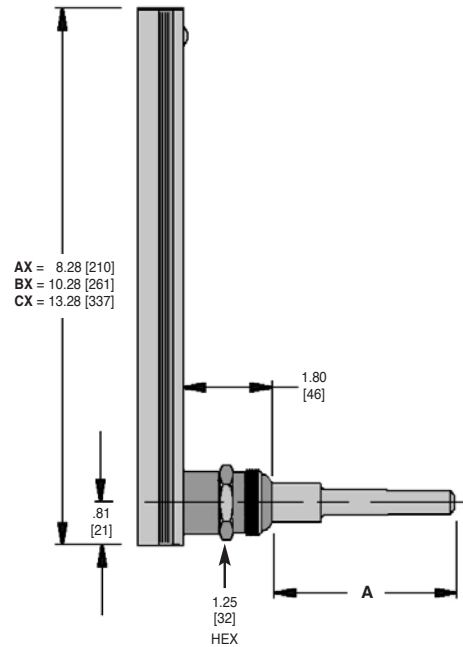

INDUSTRIAL THERMOMETERS

(A) Stem Length	Dimension
3 1/2"	3.50 [88.9]
6"	6.00 [152.4]
8"	8.00 [203.2]
12"	12.00 [304.8]

## Standard Ranges

Fahrenheit Scale		Celsius Scale		Dual Scale		Fahrenheit		Celsius	
Range Code	Range	Range Code	Range	Range Code	Range	Figure Intervals	Minor Divisions	Figure Intervals	Minor Divisions
01	-40° to 110°F	17	-40° to 40°C	41	-40° to 110°F & -40° to 40°C	10°	2°	5°	1°
02	0° to 100°F	24	-18° to 38°C	42	0° to 100°F & -18° to 38°C	5°	1°	5°	0.5°
03	30° to 130°F	25	0° to 55°C	43	30° to 130°F & 0° to 55°C	5°	1°	5°	1°
04	0° to 160°F	26	-18° to 70°C	44	0° to 160°F & -18° to 70°C	10°	2°	5°	1°
06	30° to 180°F	27	0° to 83°C	46	30° to 180°F & 0° to 83°C	10°	2°	5°	1°
07	30° to 240°F	19	0° to 115°C	47	30° to 240°F & 0° to 115°C	10°	2°	5°	1°
08	30° to 300°F	28	0° to 150°C	48	30° to 300°F & 0° to 150°C	10°	2°	10°	2°
09	50° to 400°F	28	10° to 205°C	49	50° to 400°F & 10° to 205°C	25°	5°	10°	2°
15	50° to 500°F	31	10° to 260°C	55	50° to 500°F & 10° to 260°C	25°	5°	10°	2°

Dual scale figure intervals may differ