

Thermowells

for RTD & Thermocouple Temperature Sensors

All dimensions are nominal.
Dimensions in [] are in millimeters.

CONTROLLER ACCESSORIES

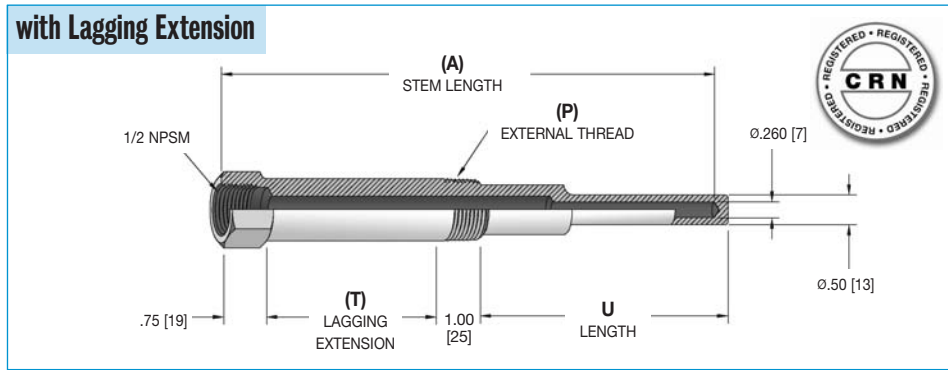
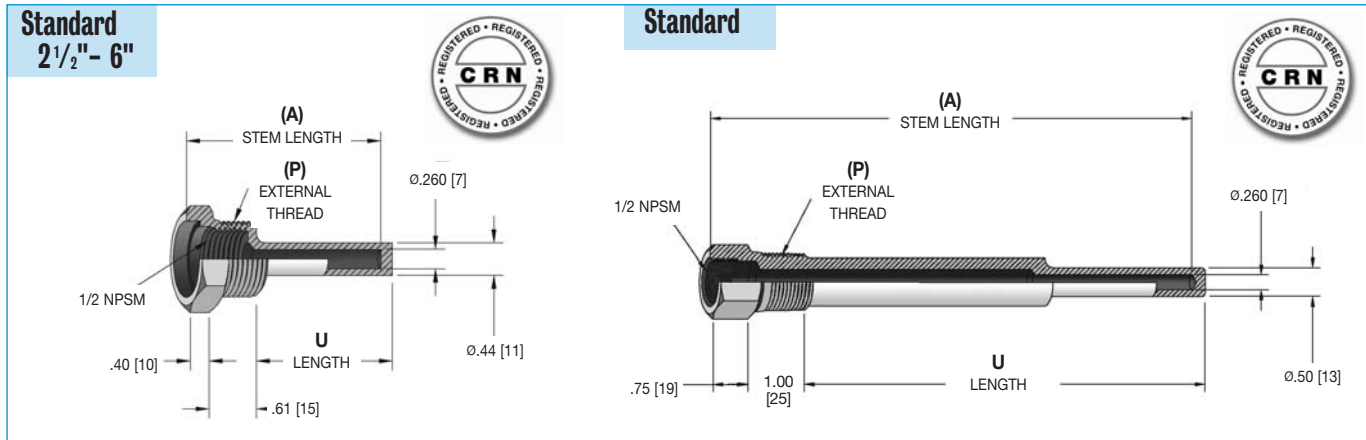

Lengths

(A) Stem Length	Standard (U) Length	Lagging (T) Lagging Extension	(U) Length
2 1/2"	1.75 [44]	—	—
4"	2.50 [64]	1.00 [25]	1.50 [38]
6"	4.50 [114]	2.00 [51]	2.50 [64]
9"	7.50 [191]	3.00 [76]	4.50 [114]
12"	10.50 [267]	3.00 [76]	7.50 [191]
15"	13.50 [343]	3.00 [76]	10.50 [267]
18"	16.50 [419]	3.00 [76]	13.50 [343]
24"	22.50 [572]	3.00 [76]	19.50 [495]

Pressure Rating (PSI)

Material	Operating Temperature					
	70°F	200°F	400°F	600°F	800°F	1000°F
Carbon steel	5000	5000	4800	4600	3500	-
304 stainless steel	6550	6000	4860	4140	3510	3130
316 stainless steel	6540	6400	6000	5270	5180	4660
Monel	5530	4990	4660	4450	4450	-
Brass	3170 psi @ 150°F, 2930 @ 350°F					

Selection of the proper thermowell is the sole responsibility of the user. Temperature and pressure limitations must be considered. Improper application may cause failure of the thermowell, resulting in possible personal injury or property damage. For correct use and application, please refer to the Thermowells For Thermometers And Electrical Temperature Sensors Standard ASME B40.9.

HOW TO ORDER

Sample Order Number: **76-4J6**

Thermowell Style	(P) External Thread	(A) Stem Length	(T) Lagging Extension	Material
76- Sensor, Stepped Shank (2 1/2" - 6" Stem Straight Shank)	3 1/2 NPT*	D 2 1/2" Stem	A 1" Extension (4" Stem only)	2 Brass
	4 3/4 NPT	G 4" Stem	C 2" Extension (6" Stem only)	3 Steel
	5 1 NPT*	J 6" Stem	E 3" Extension (9" and longer Stem only)	4 Monel
		M 9" Stem	Omit if None	5 304SS
		R 12" Stem		6 316SS
		V 15" Stem		
		Wa 18" Stem		
	Wk 24" Stem			

*Not available with 2 1/2" Stem Length

Other thermowell styles available. Please consult pages 155-161 of the Trerice Temperature Section.