

Thermowells

for L84000 Electric Contact Controllers

All dimensions are nominal. Dimensions in [] are in millimeters.

If Thermowells are to be purchased as a separate item, or if a Special Thermowell is required, please refer to this page. If a complete Electric Contact Controller is purchased, the proper Thermowell to match the sensing bulb ordered will be supplied. Please note sensing bulb size is affected by temperature range.

Indicate W02 for 1/2 NPT Brass, W05 for 1/2 NPT 304 SS or W06 for 1/2 NPT 316SS.
Indicate W12 for 3/4 NPT Brass, W15 for 3/4 NPT 304 SS or W16 for 3/4 NPT 316SS.

CONTROLLERS

Standard

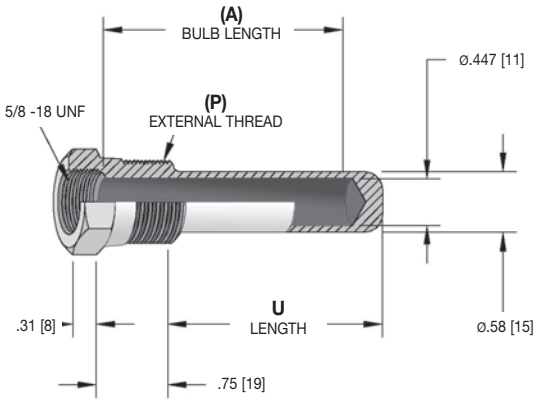

with Lagging Extension

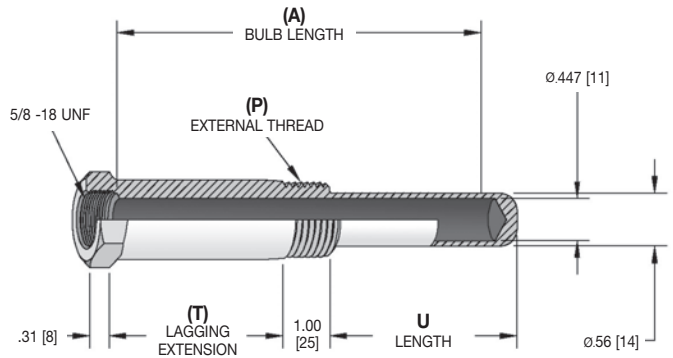

Lengths

(A) Bulb Length	Standard		Lagging	
	U Length	(T) Lagging Extension	U Length	
2"	2.13 [54]	—	—	
4"	3.88 [99]	1.50 [38]	2.13 [54]	
6"	5.75 [146]	1.50 [38]	3.88 [99]	
8"	7.75 [197]	1.50 [38]	5.75 [146]	
12"	11.75 [299]	1.50 [38]	7.50 [191]	
18"	17.75 [451]	1.50 [38]	15.75 [400]	
24"	23.75 [603]	1.50 [38]	21.75 [552]	

Pressure Rating (psi) per ASME Boiler Code, Section VIII, Part UG28

Material	Operating Temperature			
	70°F	200°F	400°F	600°F
Carbon Steel	2500	2240	2020	1640
304 Stainless Steel	2780	2280	2100	1700
316 Stainless Steel	2770	2660	2500	2300
Brass	1330 psi @ 150°F		1280 @ 350°F	

Selection of the proper thermowell is the sole responsibility of the user. Temperature and pressure limitations must be considered. Improper application may cause failure of the thermowell, resulting in possible personal injury or property damage.

HOW TO ORDER

Sample Order Number: **7-3 G 2**

Thermowell Style	(P) External Thread	Bulb Length**	(T) Lagging Extension	Material
7- Controller	3 1/2 NPT	D 2" Bulb	C 1 1/2" Extension (4" and longer Stem only) Omit if None	2 Brass 5 304SS 6 316SS
		G 4" Bulb		
	J 6" Bulb			
	L 8" Bulb			
	R 12" Bulb*			
	Wa 18" Bulb*			
	Wk 24" Bulb*			

*Not available with 1/2 NPT external thread.

**Controller Thermowells with Bulb Lengths over 6" are typically for use with Adjustable Union or Bendable Extension Connections.