

Enclosure TA302



- ▶ Polycarbonate Construction
- ▶ Aluminum Mounting Panel
- ▶ Termination Compartment
- ▶ NEMA 12 Protection

The Terrice **TA302 Enclosure** is ideal for mounting a Terrice Electronic Controller or Digital Indicator. The enclosure is constructed from rugged, impact-resistant polycarbonate and furnished with an anodized aluminum front mounting panel. It can accommodate all Terrice Electronic Control and Indicating devices.

Specifications

Model

TA302

Size 14.3" x 12.4" x 6.1"
(363 x 316 x 156 mm)

Application

Fits all electronic controls and indicating devices

Mounting

Surface

Body and Cover

Polycarbonate enclosure body and transparent cover

Hinges

Polyamide, removable for left or right side mounting

Knockouts

2 x 0.85" and 2 x 1.09"

Front Panel

Anodized aluminum

Protection

NEMA 12

Ambient Temperature

175°F (80°C) maximum

Approximate Shipping Weight

5.5 lbs [2.50 kg]

All dimensions are nominal. Dimensions in [] are in millimeters.

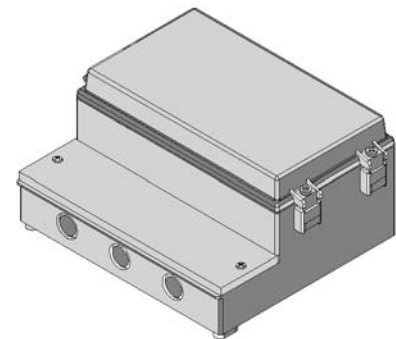
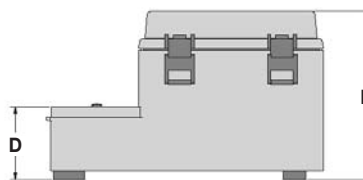
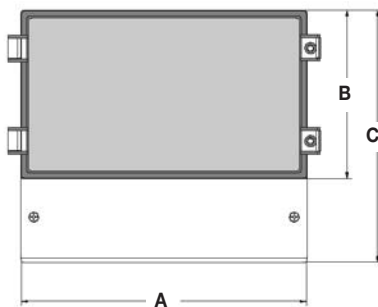

A	B	C	D	E
14.3 [363]	9.2 [234]	12.4 [316]	3.0 [78]	6.1 [156]