

# Valve Body Selection

(for 940E Series Electric Motor Control Valve)

# CAST IRON

3-WAY • 2 1/2" – 6"



All dimensions are nominal. Dimensions in [ ] are in millimeters.

CONTROL VALVES

## Mixing

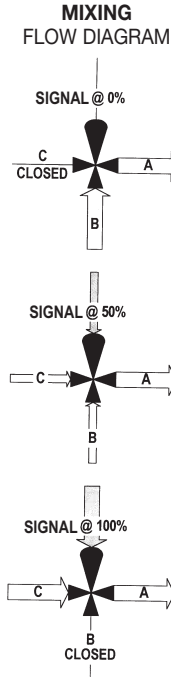
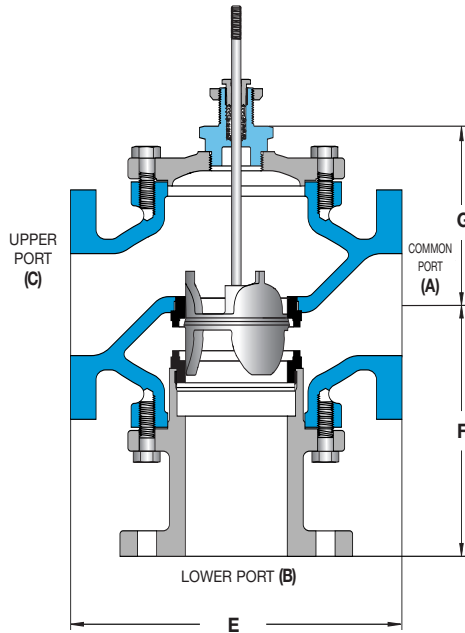

Size	Class 125			Class 250		
	E	F	G	E	F	G
2 1/2"	9.0 [229]	7.1 [180]	5.5 [140]	9.6 [244]	7.4 [188]	5.5 [140]
3"	10.0 [254]	8.0 [203]	6.1 [155]	10.8 [274]	8.4 [213]	6.1 [155]
4"	13.0 [330]	9.9 [251]	7.1 [180]	13.6 [345]	10.3 [262]	7.1 [180]
5"	15.8 [401]	9.3 [236]	6.0 [152]	16.6 [422]	10.4 [264]	6.0 [152]
6"	17.8 [452]	9.9 [251]	6.8 [173]	18.6 [472]	11.0 [279]	6.8 [173]

Trerice 3-Way Valves are not designed for use in steam applications.  
To properly control the mixing of two flows, inlet pressures at ports B and C should be as equal as possible.

## Specifications

Body Material	Trim Material	Trim Style	Connection	Pressure & Temperature Rating
Cast-iron	Stainless steel	Linear	Class 125 flanged Class 250 flanged	125 PSI @ 350°F (176°C) 250 PSI @ 400°F (204°C)

## Valve Body Selection

Valve Body Number		Size	Cv	Maximum Close-Off Pressure (psid)		Approximate* Shipping Wt.
Class 125	Class 250			30	52	
P75	Q75	2 1/2"	65	x	95	62 lbs [30 kg]
P80	Q80	3"	85	x	64	80 lbs [36 kg]
P85	Q85	4"	190	x	17	140 lbs [64 kg]
P90	Q90	5"	240	x	9	157 lbs [71 kg]
P95	Q95	6"	305	x	5	203 lbs [92 kg]

\*Shipping weights shown are for class 125 valves. Consult factory for class 250 valve weights.



### Diverting

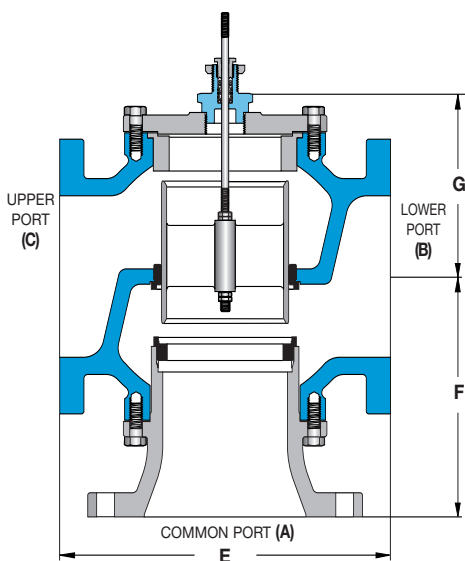

**DIVERTING FLOW DIAGRAM**

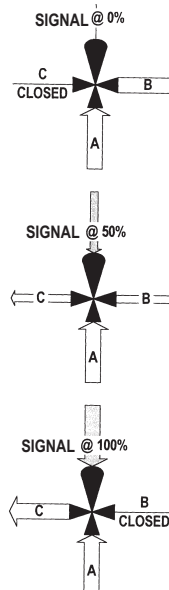

Size	Class 125			Class 250		
	E	F	G	E	F	G
2 1/2"	9.0 [229]	7.1 [180]	5.5 [140]	9.6 [244]	7.4 [188]	5.5 [140]
3"	10.0 [254]	8.0 [203]	6.1 [155]	10.8 [274]	8.4 [213]	6.1 [155]
4"	13.0 [330]	9.9 [251]	7.1 [180]	13.6 [345]	10.3 [262]	7.1 [180]
5"	12.0 [305]	10.5 [267]	7.5 [191]	12.9 [328]	11.0 [279]	7.5 [191]

Trerice 3-Way Valves are not designed for use in steam applications.

### Specifications

Body Material	Trim Material	Trim Style	Connection	Pressure & Temperature Rating
Cast-iron	Bronze	Linear	Class 125 flanged Class 250 flanged	125 PSI @ 300°F (149°C) 250 PSI @ 300°F (149°C)

### Valve Body Selection

Valve Body Number		Size	Cv	Maximum Close-Off Pressure (psid)		Approximate* Shipping Wt.
Class 125	Class 250			Linkage		
K75	L75	2 1/2"	68	30	52	62 lbs [30 kg]
K80	L80	3"	85	125	x	80 lbs [36 kg]
K85	L85	4"	160	x	125	140 lbs [64 kg]
K90	L90	5"	195	x	125	157 lbs [71 kg]

\*Shipping weights shown are for class 125 valves. Consult factory for class 250 valve weights.