

# 91000XT Series Tank Thermostat

for Oil Field Heaters, Treaters & Separators

TEMPERATURE REGULATORS



- ▶ Self-Operating Design
- ▶ Heavy Duty Die Cast Aluminum Housing
- ▶ 3/4 & 1 NPT Valve Sizes
- ▶ Soft Seated Valve for Tight Shut-Off
- ▶ Fully Enclosed Bellows

91000XT shown

The **91000XT Tank Thermostat** is specifically designed to control the temperature of heaters, treaters and separators within the petroleum industry. It is entirely self-contained, requires no external power source, and is the most widely preferred unit of its kind. When installed in a treater, the normally open valve will automatically close off the flow of gas as temperature increases, thereby regulating temperature within the treater. The Trerice 91000XT is ruggedly constructed with a heavy duty, die cast aluminum actuator housing and fully enclosed bellows assembly. Its single seated, cast-iron valve body is fitted with a stainless steel plug assembly and soft seating Viton o-ring to provide tight shut-off.

**Warning:** This valve may only be installed in outdoor applications. The Teflon v-ring packing will allow fugitive emissions to escape. Improper application may cause failure of the valve, resulting in possible personal injury or property damage.

For applications where the process media may be corrosive or contained under pressure, the use of a thermowell is required to prevent damage to the sensing bulb and facilitate its removal from the process.

For replacement or service parts please see Accessories and Replacement Parts in the Regulators and Control Valves section of the list price sheet.

## Specifications

### Model

91000XT

### Power Requirements

Fully self-contained – no external power required

### Housing

Die cast aluminum, epoxy powder coated blue finish

### Set Point Scale

Integral to housing

### Bellows

High pressure brass, corrosion resistant, tin plated finish

### Adjustment Screw

Brass

### Adjustment Screw Bushing

Lubricant impregnated sintered bronze

### Range Adjustment Spring

Cadmium plated

### Overrange Protection

Upper range limit +100°F for temporary situations

### Thermal System

Bulb: Copper, .80" x 8", with 3/4 NPT union connection for thermowell

Capillary: Copper, available in 10' or 20' lengths

### Thermowell

Steel, 1 NPT connection

### Valve

Single seat, normally open  
Body: Cast-iron

Trim: Stainless steel plug assembly with soft seating Viton o-ring, iron seat  
Port Size: 1/2"

Connection: 3/4 NPT or 1 NPT threaded ends

### Approximate Shipping Weight

10.3 lbs [4.68 kg]

## HOW TO ORDER

Sample Order Number: **91000XT X01 10 W02-X75**

Model	Range	Capillary Length	Thermowell	Valve Size
91000XT	See Standard Ranges	10 10 Feet	W02 Steel Thermowell (Omit if not required)	X75 3/4 NPT X10 1 NPT
		20 20 Feet		

# 91000XT Series Tank Thermostat

All dimensions are nominal. Dimensions in [ ] are in millimeters.

TEMPERATURE REGULATORS



## Thermostat

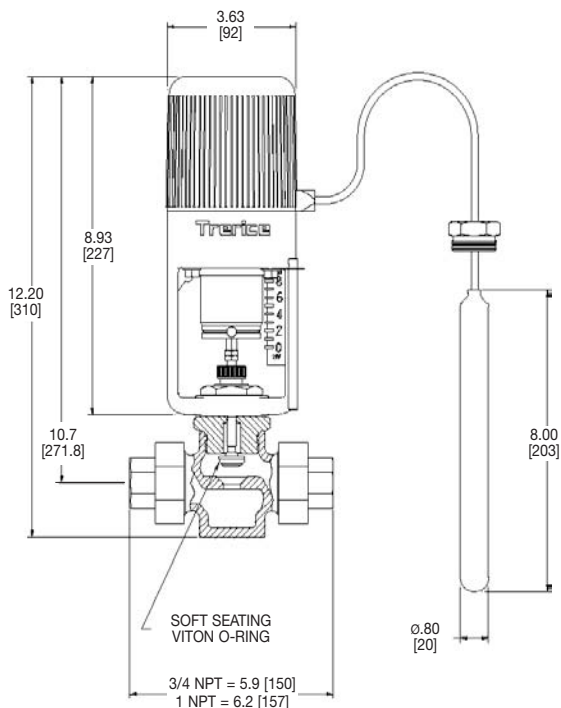

## Thermowell

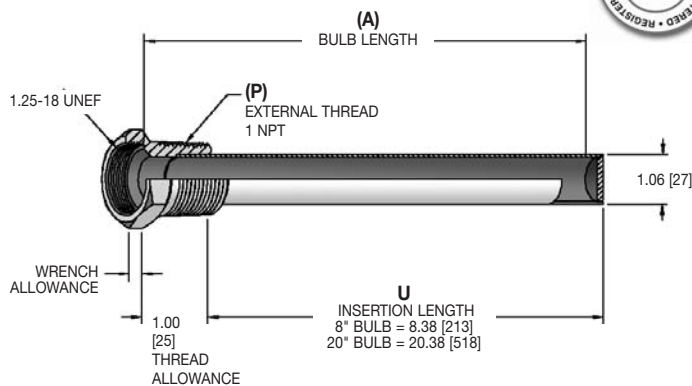

### Pressure Rating (psi)

Material	Operating Temperature		
	70°F	300°F	500°F
Carbon Steel	780	780	600

### HOW TO ORDER

Thermowell Style	(P) External Thread	Bulb Length	Material
53 Tank Thermostat	5 1 NPT	L 8" Bulb We 20" Bulb*	3 Steel

\* For ranges X07 and X08 only.

Selection of the proper thermowell is the sole responsibility of the user. Temperature and pressure limitations must be considered. Improper application may cause failure of the thermowell, resulting in possible personal injury or property damage.

If Thermowells are to be purchased as a separate item, or if a Special Thermowell is required, please refer to this page.  
If a complete Temperature Regulator is purchased, the proper Thermowell to match the sensing bulb ordered will be supplied.

## Standard Ranges

Range Code	Nominal Range	Recommended Working Span	Bulb Length (A)
X13	85° to 115°F & 30° to 45°C	85° to 115°F & 30° to 45°C	8"
X11	80° to 140°F & 25° to 60°C	110° to 140°F & 45° to 60°C	8"
X15	130° to 160°F & 50° to 70°C	130° to 160°F & 50° to 70°C	8"
X01	110° to 190°F & 45° to 90°C	160° to 190°F & 70° to 90°C	8"
X03	125° to 215°F & 55° to 100°C	180° to 210°F & 80° to 100°C	8"
X12	200° to 280°F & 95° to 135°C	250° to 280°F & 120° to 140°C	8"
X10	225° to 315°F & 110° to 155°C	280° to 310°F & 135° to 155°C	8"
X16	310° to 365°F & 155° to 185°C	310° to 365°F & 155° to 185°C	8"
X14	295° to 420°F & 145° to 215°C	360° to 420°F & 180° to 215°C	8"
X08*	45° to 115°F & 10° to 45°C	85° to 115°F & 30° to 45°C	20"
X07*	65° to 140°F & 20° to 60°C	110° to 140°F & 45° to 60°C	20"

\*Except for Range Codes X07 and X08, the actuator housing and capillary tubing must always be exposed to a temperature lower than the required control point for proper thermostat operation.

## Valve Capacities

Gas (Specific Gravity = 0.6)																		
Inlet Pressure (PSIG)	5		10		20		30		40		50							
Outlet Pressure (PSIG)	4	2	0	8	5	0	15	10	5	25	20	10	30	20	15	40	30	25
Capacity (scfh)	970	1585	1935	1450	2140	2700	2685	3480	3870	3100	4120	5030	4650	6000	6200	5320	6870	7250