

700TA Series

Sanitary Gauge with Integrated Diaphragm Seal

SPECIALTY GAUGES



700TA shown



- ▶ **2 1/2", 4" Dial Sizes**
- ▶ **Stainless Steel Case**
- ▶ **Liquid Fillable**
- ▶ **1 1/2", 2" Tri-clamp Type Connections**

The Trerice **700TA Series** Sanitary Gauge is 3A approved and especially suited for use in the dairy and food processing industries. This field liquid fillable (no kit required) gauge has a stainless steel case, ring, and process housing. All wetted parts are stainless steel.

- Optional features and case style variations available: Please consult the Options & Accessories Section for details.
- Please refer to 3A Standard 37-01, 3A Standard for Liquid Pressure and Level Sensing Devices
- For correct use and application of all pressure gauges, please refer to: Pressure Gauge Standard ASME B40.100.

HOW TO ORDER

Sample Order Number: **700TA 40 15T L A 130**

Model	Dial Size	Connection Size	Connection Location	Units of Measure	Range Code
700TA	25 2 1/2"	15T 1 1/2" Tri-Clamp	L Lower	A psi	See Standard Ranges
700TALF	40 4"	20T 2" Tri-Clamp	B Back	D psi/kPa	

Specifications

Models

700TA (dry)
700TALF (liquid filled)

Dial Sizes 2 1/2", 4"

Wetted Parts

316 stainless steel diaphragm

Fill

Glycerine, other fills available. See Options & Accessories.

Movement

Stainless steel

Connection

2 1/2" Dial Size: Lower or center back Tri-clamp, 1 1/2" or 2"
 4" Dial Size: Lower or lower back, Tri-clamp, 1 1/2" or 2"

Case

304 stainless steel, stem mounted flangeless

Ring

Crimped 304 stainless steel, highly polished

Window

Safety glass

Pointer

Plain black finished

Dial Face

Aluminum, white background with black graduations and markings

Accuracy

±1.6% Full Scale

Maximum Temperature

250°F (121°C)

Approximate Shipping Weight

- 700TA 2 1/2" Dial Size, 1 1/2" Tri-clamp, 1.4 lbs [0.64 kg]
- 700TA 2 1/2" Dial Size, 2" Tri-clamp, 1.9 lbs [0.86 kg]
- 700TALF 2 1/2" Dial Size, 1 1/2" Tri-clamp, 1.9 lbs [0.86 kg]
- 700TALF 2 1/2" Dial Size, 2" Tri-clamp, 2.6 lbs [1.18 kg]
- 700TA 4" Dial Size, 1 1/2" Tri-clamp, 2.6 lbs [1.18 kg]
- 700TA 4" Dial Size, 2" Tri-clamp, 3.3 lbs [1.50 kg]
- 700TALF 4" Dial Size, 1 1/2" Tri-clamp, 3.3 lbs [1.50 kg]
- 700TALF 4" Dial Size, 2" Tri-clamp, 4.0 lbs [1.81 kg]

700TA Series

Sanitary Gauge with Integrated Diaphragm Seal

All dimensions are nominal. Dimensions in [] are in millimeters.

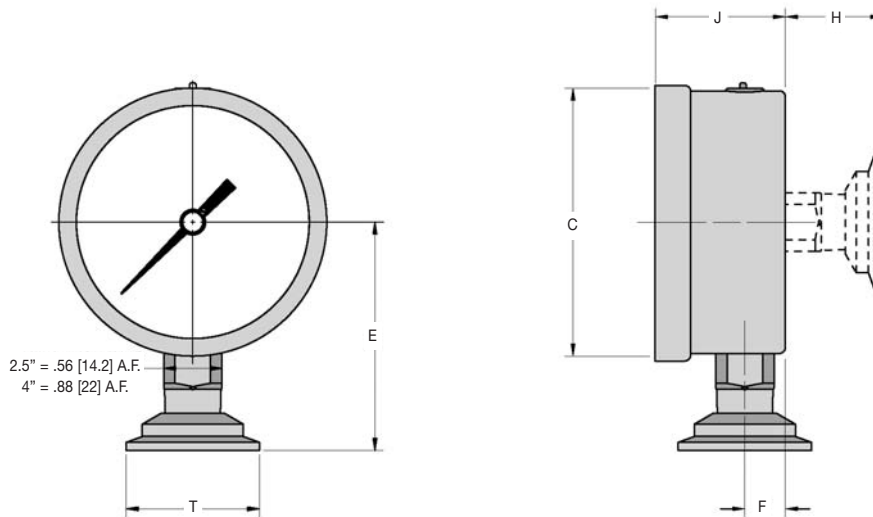

Clamps, gaskets and ferrules are not supplied by Terrice.

Dial Size	Tri-Clamp Size	C	E	F	H	J	T
2 1/2" [63]	1 1/2"	2.68 [68]	2.64 [67]	0.37 [9.5]	1.52 [38.5]	1.20 [30.5]	1.98 [50.5]
	2"	2.68 [68]	2.64 [67]	0.37 [9.5]	1.52 [38.5]	1.20 [30.5]	2.51 [64.0]
4" [100]	1 1/2"	4.18 [106.2]	3.35 [85]	0.46 [11.8]	1.52 [38.5]	1.32 [33.5]	1.98 [50.5]
	2"	4.18 [106.2]	3.35 [85]	0.46 [11.8]	1.52 [38.5]	1.32 [33.5]	2.51 [64.0]

Standard Ranges

psi Ranges (A)			
Range Code	Specific Range	Figure Intervals	Minor Divisions
010	30" Hg to 0	5	0.5
020	30" Hg to 15 psi	10/5	10/0.5
030	30" Hg to 30 psi	10/10	2/1
040	30" Hg to 60 psi	30/20	2/2
050	30" Hg to 100 psi	30/20	5/2
060	30" Hg to 150 psi	30/20	10/2
070	30" Hg to 300 psi	30/30	5/10
080	0 to 15 psi	3	0.2
090	0 to 30 psi	5	0.5

psi Ranges (A)		
Range Code	Specific Range	Figure Intervals
100	0 to 60 psi	10
110	0 to 100 psi	20
120	0 to 160 psi	20
130	0 to 200 psi	50
140	0 to 300 psi	50
150	0 to 400 psi	100
160	0 to 600 psi	100
180	0 to 1000 psi	200

For dual scale ranges, specify the appropriate **Units of Measure: D** (psi/kPa) followed by the corresponding **A** (psi) **Range Code**. Other pressure ranges are also available including: Altitude, Ammonia, Refrigerant and Receiver. Consult Special Application Ranges section or factory for availability.

SPECIALTY GAUGES