

# 610CB

## Glass Filled Nylon Case

COMMERCIAL • CONTRACTOR GAUGES



610CB shown



- ▶ 4 1/2" Dial Size
- ▶ ±1.0% Accuracy
- ▶ Back Flanged, Glass Filled Nylon Case
- ▶ Adjustable Pointer

The **610CB** Trerice Contractor Gauge is designed to service the pressure measurement requirements of the construction and transportation industries. The 610CB is furnished with a corrosion resistant plastic case and an adjustable pointer. Wetted parts are a bronze tube with brass socket.

- Optional features available: Please consult the Options & Accessories Section for details.
- For correct use and application of all pressure gauges, please refer to: Pressure Gauge Standard ASME B40.100.

### Specifications

<b>Model</b>	610CB
<b>Dial Size</b>	4 1/2"
<b>Wetted Parts</b>	Bronze tube, brass socket
<b>Movement</b>	Brass
<b>Connection</b>	Lower male, 1/4 NPT
<b>Case</b>	Glass filled nylon, surface mounted back flanged
<b>Ring</b>	Friction type, 304 stainless steel
<b>Window</b>	Clear glass
<b>Pointer</b>	Adjustable, black finished
<b>Dial Face</b>	Aluminum, white background with black graduations and markings
<b>Accuracy</b>	±1.0% Full Scale, ASME B40.100 Grade 1A
<b>Maximum Temperature</b>	250°F (121°C)
<b>Approximate Shipping Weight</b>	0.9 lbs [0.41 kg]

### HOW TO ORDER

Sample Order Number: **610CB 45 02 L A 110**

Model	Dial Size	Connection Size	Connection Location	Units of Measure	Range Code
610CB	45 4 1/2"	02 1/4 NPT	L Lower	A psi B kPa C kg/cm <sup>2</sup> D psi/kPa E psi & kg/cm <sup>2</sup>	See Standard Ranges

All dimensions are nominal. Dimensions in [ ] are in millimeters.

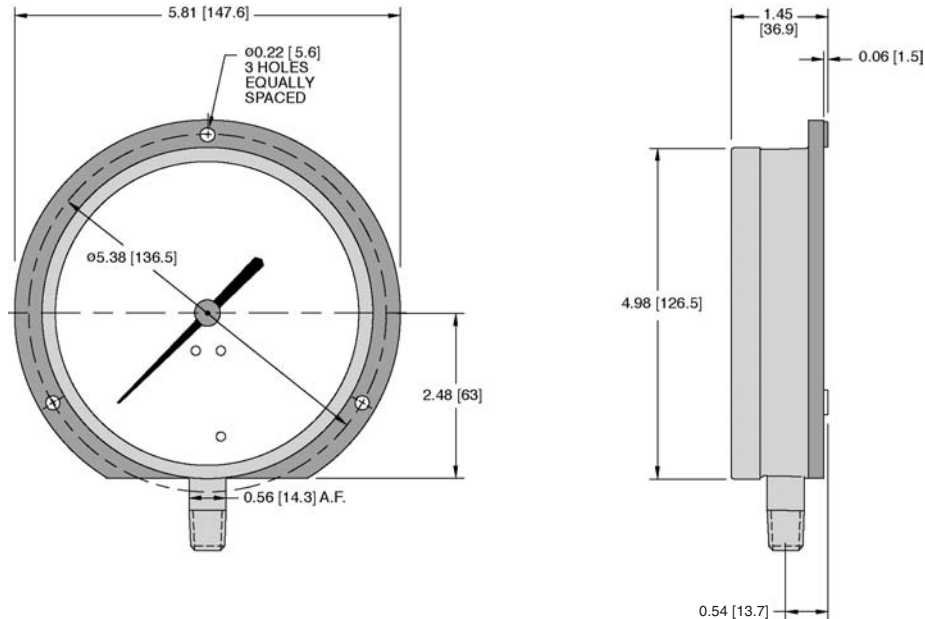

### Standard Ranges

psi Ranges (A)				kPa Ranges (B)				kg/cm <sup>2</sup> Ranges (C)			
Range Code	Specific Range (psi)	Figure Intervals	Minor Divisions	Range Code	Specific Range	Figure Intervals	Minor Divisions	Range Code	Specific Range	Figure Intervals	Minor Divisions
010	30" Hg to 0	5	0.2	010	-100 to 0 kPa	10	1	010	76 cm Hg to 0	10	0.5
020	30" Hg to 15 psi	5/5	0.5/0.2	020	-100 to 100 kPa	20	2	020	76 cm Hg to 1 kg/cm <sup>2</sup>	20/0.2	1/.02
030	30" Hg to 30 psi	10/5	1/0.5	030	-100 to 200 kPa	50	2	030	76 cm Hg to 2 kg/cm <sup>2</sup>	20/0.5	2/.02
040	30" Hg to 60 psi	10/10	1/1	040	-100 to 400 kPa	50	5	040	76 cm Hg to 4 kg/cm <sup>2</sup>	25/0.5	5/.05
050	30" Hg to 100 psi	30/10	2/1	050	-100 to 700 kPa	100	5	050	76 cm Hg to 7 kg/cm <sup>2</sup>	76/1	5/0.1
060	30" Hg to 150 psi	30/20	5/2	060	-100 to 1000 kPa	100	10	060	76 cm Hg to 10 kg/cm <sup>2</sup>	76/1	15/0.1
070	30" Hg to 300 psi	30/50	5/2	070	-100 to 2000 kPa	200	20	070	76 cm Hg to 21 kg/cm <sup>2</sup>	76/2	19/0.2
080	0 to 15 psi	3	0.1	080	0 to 100 kPa	10	1	080	0 to 1 kg/cm <sup>2</sup>	0.1	0.01
090	0 to 30 psi	5	0.2	090	0 to 200 kPa	20	2	090	0 to 2 kg/cm <sup>2</sup>	0.2	0.02
100	0 to 60 psi	10	0.5	100	0 to 400 kPa	50	5	100	0 to 4.2 kg/cm <sup>2</sup>	0.5	0.05
110	0 to 100 psi	10	1	110	0 to 700 kPa	100	5	110	0 to 7 kg/cm <sup>2</sup>	1	0.05
120	0 to 160 psi	20	1	120	0 to 1200 kPa	200	10	120	0 to 11 kg/cm <sup>2</sup>	1	0.1
130	0 to 200 psi	20	2	130	0 to 1500 kPa	300	10	130	0 to 14 kg/cm <sup>2</sup>	2	0.1
140	0 to 300 psi	50	2	140	0 to 2000 kPa	200	20	140	0 to 21 kg/cm <sup>2</sup>	3	0.2
150	0 to 400 psi	50	5	150	0 to 3000 kPa	300	20	150	0 to 28 kg/cm <sup>2</sup>	4	0.2
160	0 to 600 psi	50	5	160	0 to 4000 kPa	500	50	160	0 to 42 kg/cm <sup>2</sup>	6	0.5
180	0 to 1000 psi	100	10	180	0 to 7000 kPa	1000	50	180	0 to 70 kg/cm <sup>2</sup>	10	0.5

For dual scale ranges, specify the appropriate Units of Measure: **D** (psi/kPa) or **E** (psi & kg/cm<sup>2</sup>) followed by the equivalent **A** (psi) Range Code. Other pressure ranges are also available including: Altitude, Ammonia, Refrigerant and Receiver. Consult Special Application Ranges section or factory for availability.