

735/740 Series

Needle Valves

735/740 Series Needle Valves are of the rising stem type and are designed to shut off the flow of the process media to the pressure instrument, thereby allowing the instrument to be isolated from the pressure media or removed from service. Needle valves may also be used to throttle flow and aid in dampening pulsations. Trerice Needle Valves are constructed from brass, carbon steel and stainless steel for use on a variety of pressure media.

It is recommended to place a needle valve, ball valve or gauge cock in line before every pressure gauge installation.



735-2
735-4

735-8
740-3
740-11

735-9
740-4
740-9

735/740 Series Needle Valves

Item No.	Type	Connection Size (NPT)	Body	Seat	Stem	Packing	Maximum Pressure (psig)	Maximum Temperature	Approximate Shipping Weight
735-2	F X F	1/4	Brass*	Brass	Brass	Teflon	2000	200°F	0.3 lbs [0.14 kg]
735-4	F X F	1/4	Carbon steel	Teflon	316SS	Teflon	4000	200°F	0.3 lbs [0.14 kg]
735-8	F X F	1/4	316SS	316SS	316SS	Teflon	6000	200°F	0.3 lbs [0.14 kg]
735-9	M X F	1/4	316SS	316SS	316SS	Teflon	6000	200°F	0.3 lbs [0.14 kg]
740-3	F X F	1/2	Carbon steel	Carbon steel	316SS	Teflon	10,000	200°F	1.0 lbs [0.45 kg]
740-4	M X F	1/2	Carbon steel	Carbon steel	316SS	Teflon	10,000	200°F	1.3 lbs [0.59 kg]
740-9	M X F	1/2	316SS	Delrin	316SS	Teflon	6000	200°F	1.3 lbs [0.59 kg]
740-11	F X F	1/2	316SS	316SS	316SS	Teflon	10,000	200°F	1.0 lbs [0.45 kg]

* Add (PBF) to the end of part number to specify Lead-Free brass.

All dimensions are nominal. Dimensions in [] are in millimeters.

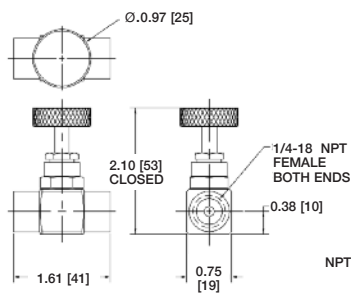

PART NO. 735-2

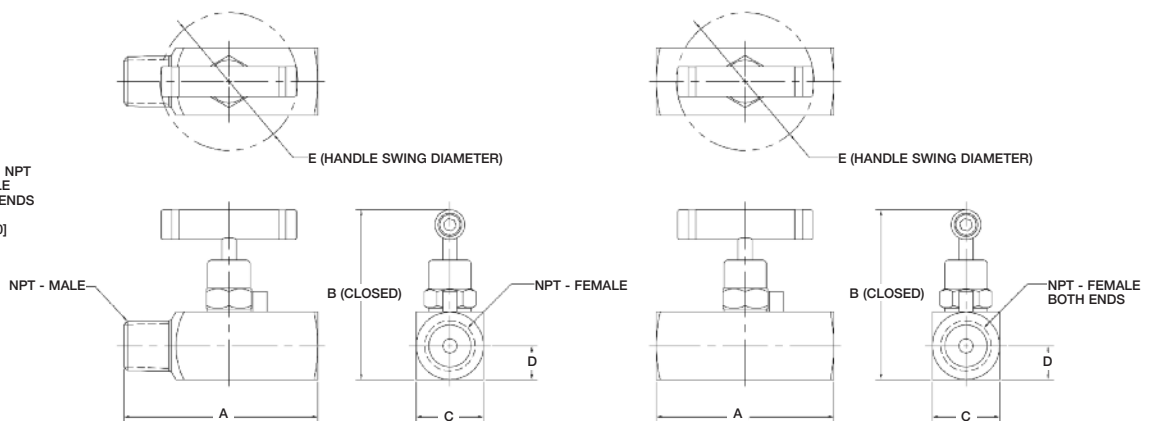

Part No.	A	B	C	D	E	NPT
735-9	2.29 [58]	2.39 [61]	0.75 [19]	0.38 [10]	1.87 [47]	1/4 - 18
740-4	3.23 [82]	2.83 [72]	1.13 [29]	0.56 [14]	2.29 [58]	1/2 - 14

Part No.	A	B	C	D	E	NPT
735-4	2.29 [58]	2.39 [61]	0.75 [19]	0.38 [10]	1.87 [47]	1/4 - 18
740-3	2.96 [75]	2.83 [72]	1.13 [29]	0.56 [14]	2.29 [58]	1/2 - 14