

Test Gauges

For Gas or Water Service

UTILITY GAUGES



Gas Test Gauge



Water Test Gauge

- ▶ **Gas Test: 2" Dial**
- ▶ **Water Test: 2 1/2" Dial**
- ▶ **Gas Test: 3/4 NPT Female**
- ▶ **Water Test: 3/4 NPT Hose Bib**

Trerice **Gas** and **Water Test Gauges** are integral tools for passing building inspections. Once the system has been pressurized, any leaks are visible as a pressure drop on the dial of the Gas Test Gauge. The Water Test Gauge has a 3/4 NPT hose bib connection mounted at 12 o'clock for easy viewing and accurately measures in-line water pressure. A maximum register pointer is available on either gauge having a dial range of 60 psi or greater.

Specifications

Models

120	Gas Test Gauge
122	Water Test Gauge

Dial Sizes	Gas Test: 2" (50mm) Water Test: 2 1/2" (63mm)
-------------------	--

Wetted Parts

Bronze tube, lead-free (PBF) brass socket

Connection	Gas Test: 3/4 NPT female Water Test: 3/4 female hose-bib connection, 12 o'clock mount
-------------------	--

Case	Steel, black painted
-------------	----------------------

Ring	Steel, black painted
-------------	----------------------

Window	Acrylic
---------------	---------

Pointer	Steel, black painted Adjustable via screw on dial face
----------------	---

Accuracy	3-2-3%, Grade B
-----------------	-----------------

Maximum Temperature

150°F (65°C)

Approximate Shipping Weight

2" Gas Test:
0.6 lbs. (0.27 kg)

2 1/2" Water Test:
0.4 lbs. (0.18 kg)

Gas Test Gauge Part Number *	Water Test Gauge Part Number *	Range
PGT12010	N/A	0 to 15 psi
PGT120190	N/A	0 to 15 psi/kPa
PGT120191	N/A	0 to 30 psi/kPa
PGT120192	N/A	0 to 60 psi/kPa
PGT120193	N/A	0 to 100 psi/kPa
N/A	PWT122194	0 to 160 psi/kPa
N/A	PWT122196	0 to 300 psi/kPa

* Add MAX to any part number for Maximum Registering Pointer. (60 psi and greater only)

Example: PGT120192MAX

Test Gauges

For Gas or Water Service

All dimensions are nominal. Dimensions in [] are in millimeters.

WATER TEST GAUGE

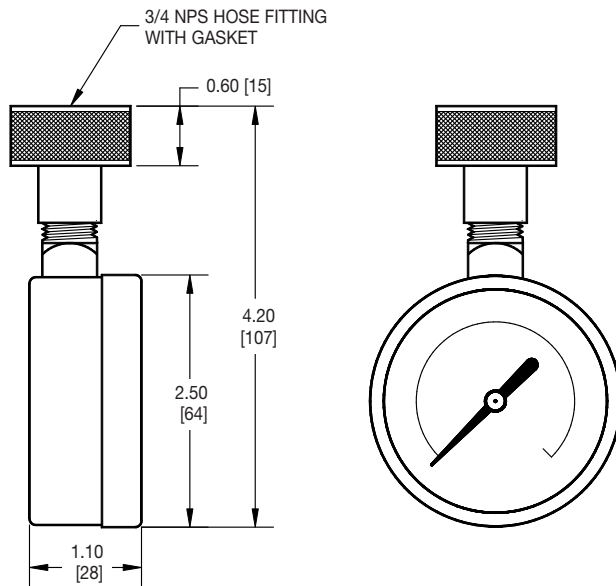

GAS TEST GAUGE

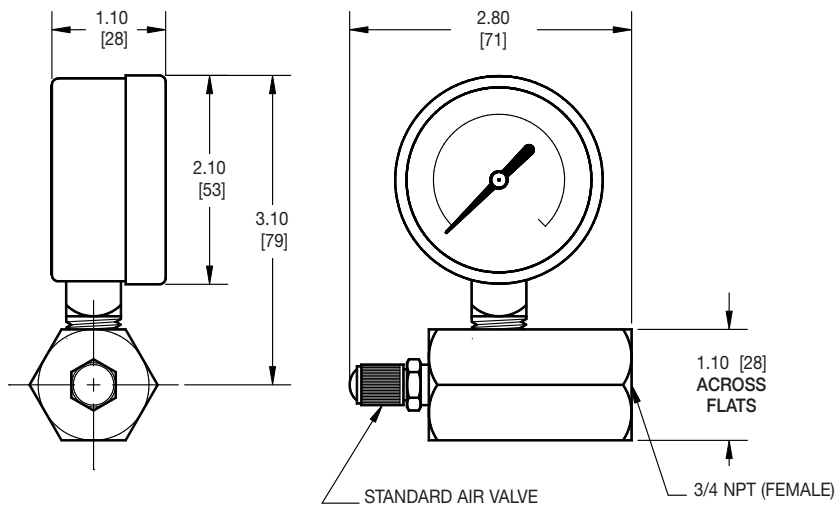

UTILITY GAUGES