

Valve Body Selection

(for 940 Series Heavy Duty Control Valve)

CAST IRON

3-WAY • 2 1/2" – 8"



All dimensions are nominal. Dimensions in [] are in millimeters.

CONTROL VALVES

Mixing

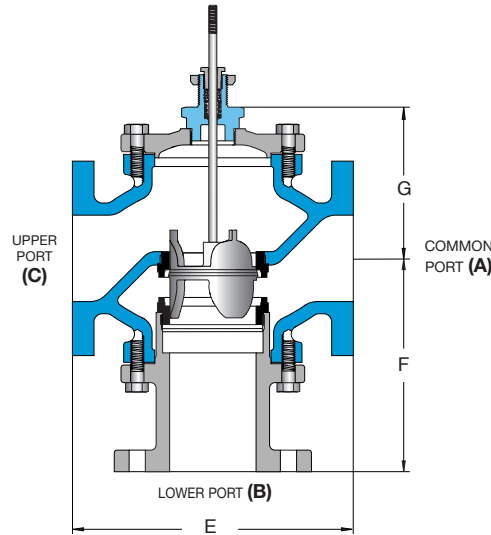

MIXING FLOW DIAGRAM

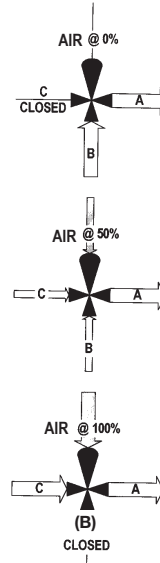

Mixing Size	Class 125			Class 250		
	E	F	G	E	F	G
2 1/2"	9.0 [229]	7.1 [180]	5.5 [140]	9.6 [244]	7.4 [188]	5.5 [140]
3"	10.0 [254]	8.0 [203]	6.1 [155]	10.8 [274]	8.4 [213]	6.1 [155]
4"	13.0 [330]	9.9 [251]	7.1 [180]	13.6 [345]	10.3 [262]	7.1 [180]
5"	15.8 [401]	9.3 [236]	6.0 [152]	16.6 [422]	10.4 [264]	6.0 [152]
6"	17.8 [452]	9.9 [251]	6.8 [173]	18.6 [472]	11.0 [279]	6.8 [173]
8"	16.3 [414]	11.9 [302]	8.6 [218]	16.3 [414]	12.4 [315]	8.6 [218]

Trerice 3-Way Valves are not designed for use in steam applications.

To properly control the mixing of two flows, inlet pressures at ports B and C should be as equal as possible.

Specifications

Body Material	Trim Material	Trim Style	Connection	Pressure & Temperature Rating
Cast-iron	Stainless steel	Linear	Class 125 flanged Class 250 flanged	125 PSI @ 350°F (176°C) 250 PSI @ 400°F (204°C)

Valve Body Selection

Mixing				Maximum Close-Off Pressure (psid)				Approximate* Shipping Wt.
Valve Body Number		Size	C _v	Actuator				
Class 125	Class 250			940B	940B w/Positioner	940C	940C w/Positioner	
P75	Q75	2 1/2"	65	20	111	44	185	62 lbs [30 kg]
P80	Q80	3"	85	11	75	28	126	80 lbs [36 kg]
P85	Q85	4"	190	4	40	13	68	140 lbs [64 kg]
P90	Q90	5"	240	x	24	7	42	157 lbs [71 kg]
P95	Q95	6"	347	x	6	x	12	203 lbs [92 kg]
P100	Q100	8"	450	x	x	x	11	324 lbs [148 kg]

* Shipping weights shown are for Class 125 Valves. Consult factory for Class 250 valve weights.

CAST IRON

All dimensions are nominal. Dimensions in [] are in millimeters.



Valve Body Selection

(for 940 Series Heavy Duty Control Valve)

3-WAY • 2 1/2" – 8"

Diverting

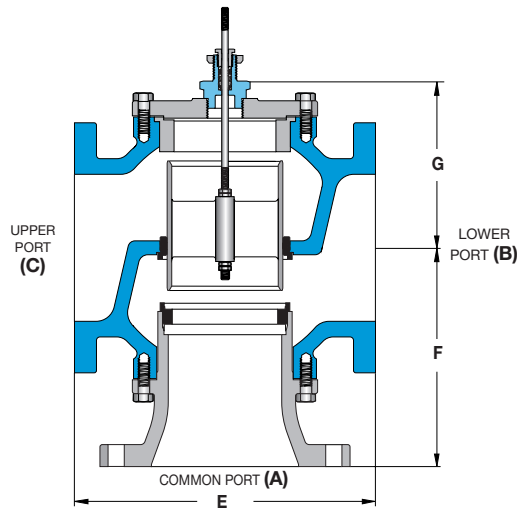

DIVERTING FLOW DIAGRAM

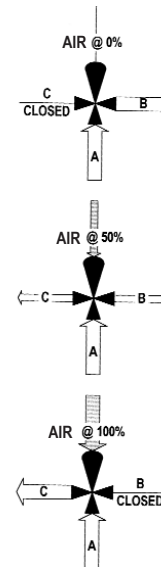

CONTROL VALVES

Diverting Size	Class 125			Class 250		
	E	F	G	E	F	G
2 1/2"	9.0 [229]	7.1 [180]	5.5 [140]	9.6 [244]	7.4 [188]	5.5 [140]
3"	10.0 [254]	8.0 [203]	6.1 [155]	10.8 [274]	8.4 [213]	6.1 [155]
4"	13.0 [330]	9.9 [251]	7.1 [180]	13.6 [345]	10.3 [262]	7.1 [180]
5"	12.0 [305]	10.5 [267]	7.5 [191]	12.9 [328]	11.0 [279]	7.5 [191]
6"	14.1 [358]	11.1 [282]	7.9 [201]	14.5 [368]	11.5 [292]	7.9 [201]
8"	16.3 [414]	11.9 [302]	8.6 [218]	16.3 [414]	12.4 [315]	8.6 [218]

Trerice 3-Way Valves are not designed for use in steam applications.

To properly control the mixing of two flows, inlet pressures at ports B and C should be as equal as possible.

Specifications

Body Material	Trim Material	Trim Style	Connection	Pressure & Temperature Rating
Cast-iron	Bronze	Linear	Class 125 flanged Class 250 flanged	125 PSI @ 300°F (149°C) 250 PSI @ 300°F (149°C)

Valve Body Selection

Diverting		Maximum Close-Off Pressure (psid)						Approximate* Shipping Wt.
Valve Body Number		Size	Cv	Actuator				
Class 125	Class 250			940B	940B w/Positioner	940C	940C w/Positioner	
K75	L75	2 1/2"	68	x	125	x	x	62 lbs [30 kg]
K80	L80	3"	85	x	125	x	x	80 lbs [36 kg]
K85	L85	4"	160	x	125	x	x	140 lbs [64 kg]
K90	L90	5"	195	x	125	x	x	157 lbs [71 kg]
K95	L95	6"	270	x	x	x	125	203 lbs [92 kg]
K100	L100	8"	425	x	x	x	125	329 lbs [150 kg]

* Shipping weights shown are for Class 125 Valves. Consult factory for Class 250 valve weights.