

# STAINLESS STEEL

# Valve Body Selection (for 940 Series Heavy Duty Control Valve)

All dimensions are nominal. Dimensions in [ ] are in millimeters.



3-WAY • 1/2" - 2"

## Mixing

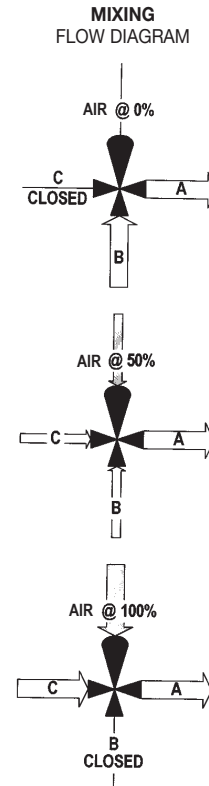
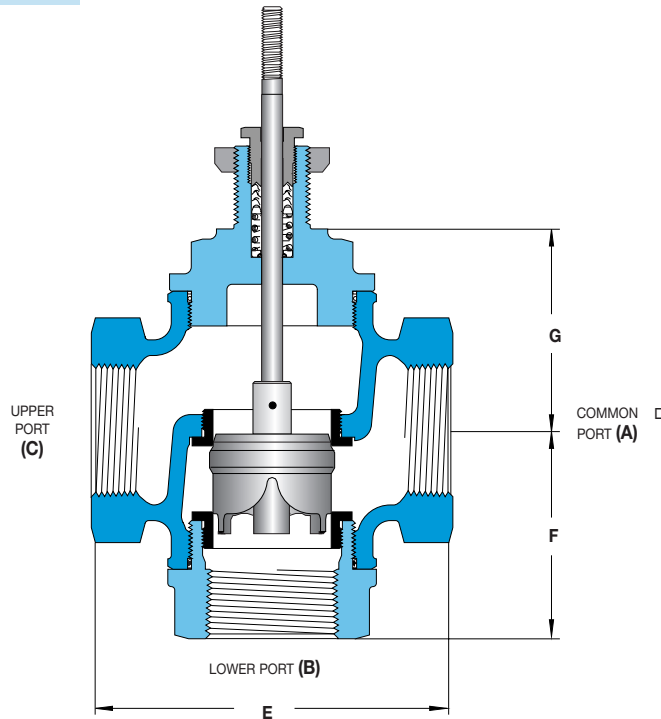

CONTROL VALVES

Tretrice 3-Way Valves are not designed for use in steam applications. To properly control the mixing of two flows, inlet pressures at ports B and C should be as equal as possible.

## Specifications

Body Material	Trim Material	Trim Style	Connection	Pressure & Temperature Rating
Stainless steel	Stainless steel	Linear	Threaded	515 PSI @ 400°F (204°C)

## Valve Selection

Mixing	Size			Maximum Close-Off Pressure (psid)		Dimensions			Approximate Shipping Wt.
	Valve Body Number	Connection (NPT)	Nominal Port	C <sub>v</sub>	940B	940B w/Positioner	E	F	
M18	1/2	1/2"	6.3	105	557	5.0 [127]	2.9 [74]	2.9 [74]	7.5 lbs [3.41 kg]
M25	3/4	3/4"	8.2	105	557	5.0 [127]	2.9 [74]	2.9 [74]	7.5 lbs [3.41 kg]
M34	1	1"	10	105	557	5.0 [127]	2.9 [74]	2.9 [74]	7.0 lbs [3.18 kg]
M56	1 1/2	1 1/2"	20	32	236	6.1 [155]	3.4 [86]	3.5 [89]	15.0 lbs [6.82 kg]
M67	2	2"	40	12	138	6.5 [165]	3.8 [97]	3.8 [97]	18.5 lbs [8.41 kg]