

CAST IRON

Valve Body Selection

(for 940E Series Electric Motor Control Valve)

All dimensions are nominal. Dimensions in [] are in millimeters.



Single Seat • 2 1/2" – 5"

Stem In-To-Close

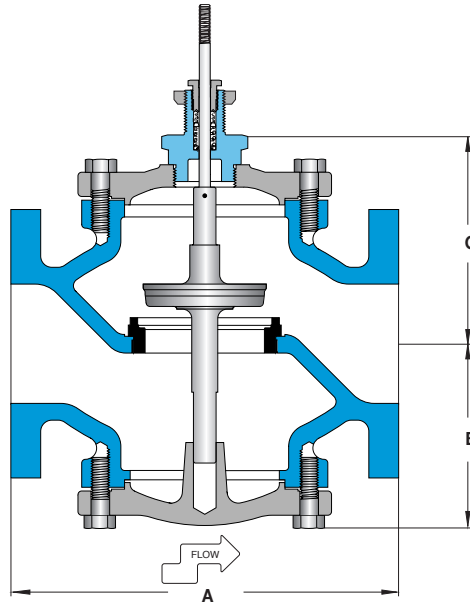

CONTROL VALVES

Size	Class 125			Class 250		
	A	B	C	A	B	C
2 1/2"	9.0 [229]	4.9 [124]	5.5 [140]	9.6 [244]	4.9 [124]	5.5 [140]
3"	10.0 [254]	5.5 [140]	6.9 [175]	10.8 [274]	5.5 [140]	6.9 [175]
4"	13.0 [330]	6.4 [163]	7.1 [180]	13.6 [345]	6.4 [163]	7.1 [180]
5"	15.8 [401]	5.8 [147]	7.8 [198]	16.6 [422]	5.8 [147]	7.8 [198]

Specifications

Body Material	Trim Material	Trim Style	Connection	Pressure & Temperature Rating
Cast-iron	Stainless steel	Equal percentage	Class 125 flanged Class 250 flanged	125 PSI @ 350°F (176°C) 250 PSI @ 400°F (204°C)

Valve Body Selection

In-To-Close				Maximum Close-Off Pressure (psid)		Approximate Shipping Wt.
Class 125	Class 250	Size	C _v	30	52	
K71	L71	2 1/2"	65	x	95	50 lbs [23 kg]
K76	L76	3"	90	x	64	95 lbs [43 kg]
K81	L81	4"	170	x	33	130 lbs [59 kg]
K86	L86	5"	280	x	9	150 lbs [68 kg]