

# Optional Case Styles

## 500X Series

All dimensions are nominal. Dimensions in [ ] are in millimeters.

OPTIONS & ACCESSORIES

**How to Order:** Specify the Optional Case Code at the end of the Instrument Ordering Code.

Sample Order Number: **500XB 45 02 LA 110 - FSL**

Optional Case Styles for 500X	Dial Size			
	4 1/2"	6"	8 1/2"	12"
Flangeless, Black Finished, Cast Aluminum Case, Lower Connection	FSL	FSL	N/A	N/A
Flangeless, Black Finished, Cast Aluminum Case, Back Connection	FSB	FSB	N/A	N/A
Panel Mounted, Hinged Ring Case Back Connection	HRB	HRB	N/A	HRB
Panel Mounted, Hinged Ring Case Lower Connection	HRL	HRL	N/A	HRL

N/A = Not available. Please order using the code listed.

### Flangeless

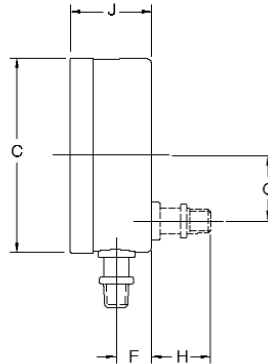
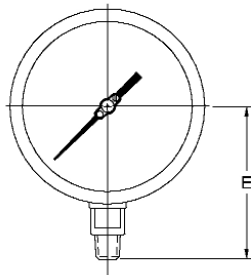

Dial Size	C	E	F	G	H	J
4 1/2"	4.79 [121.7]	3.83 [97.2]	.94 [23.8]	1.63 [41.3]	1.46 [37.1]	2.00 [50.8]
6"	6.29 [159.8]	4.70 [119.5]	.94 [23.8]	1.63 [41.3]	1.46 [37.1]	2.03 [51.6]

### Hinged Ring

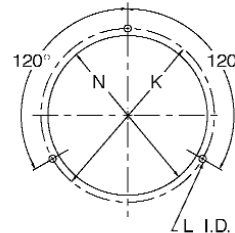
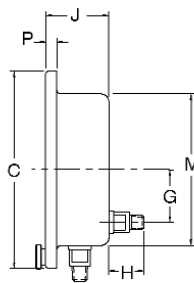
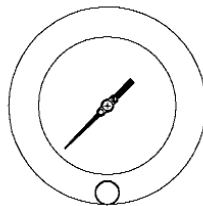

Dial Size	C	G	H	J	K	L	M	N	P
4 1/2"	6.10 [155]	1.62 [41]	1.59 [40]	1.97 [50]	5.38 [136]	0.22 [5]	4.78 [121]	4.94 [125]	0.34 [8]
6"	7.69 [195]	1.62 [41]	1.59 [40]	1.97 [50]	7.00 [177]	0.28 [7]	6.22 [158]	6.44 [163]	0.34 [8]
12"	14.75 [375]	1.62 [41]	1.38 [35]	2.50 [63.5]	13.50 [342]	0.28 [7]	12.50 [317]	12.81 [325]	0.73 [18.5]

# Optional Case Styles

## 600C

All dimensions are nominal. Dimensions in [ ] are in millimeters.

OPTIONS & ACCESSORIES

**Kit Only. Not Factory installed.**

	Dial Size	
<b>Optional Case Style - 600C</b>	<b>3 1/2"</b>	<b>4 1/2"</b>
Surface Mounted Back Flange Kit	115-0248	198-0016

Please order using the code listed.

**3 1/2"** Includes back flange. Use existing screws from gauge.

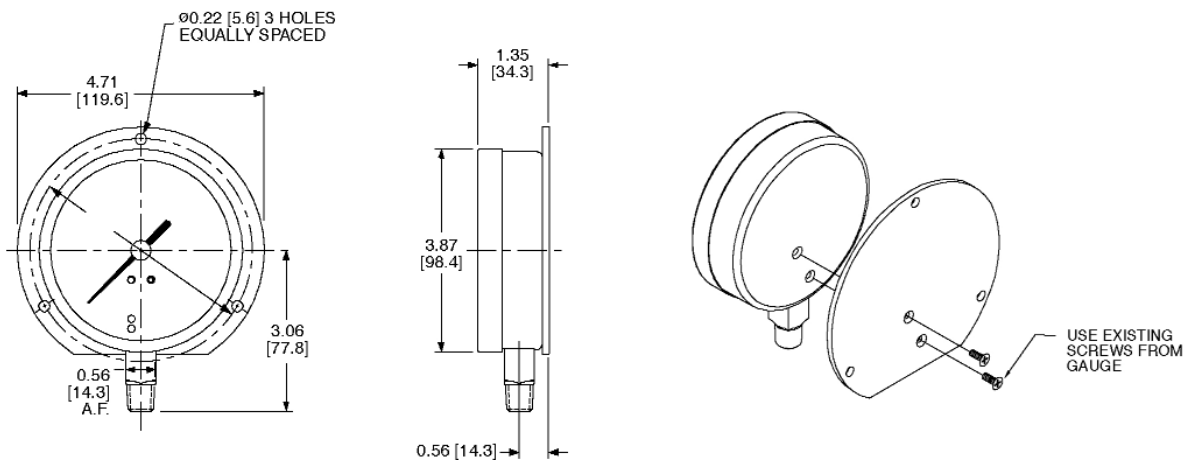

**4 1/2"** Includes back flange and replacement screws.

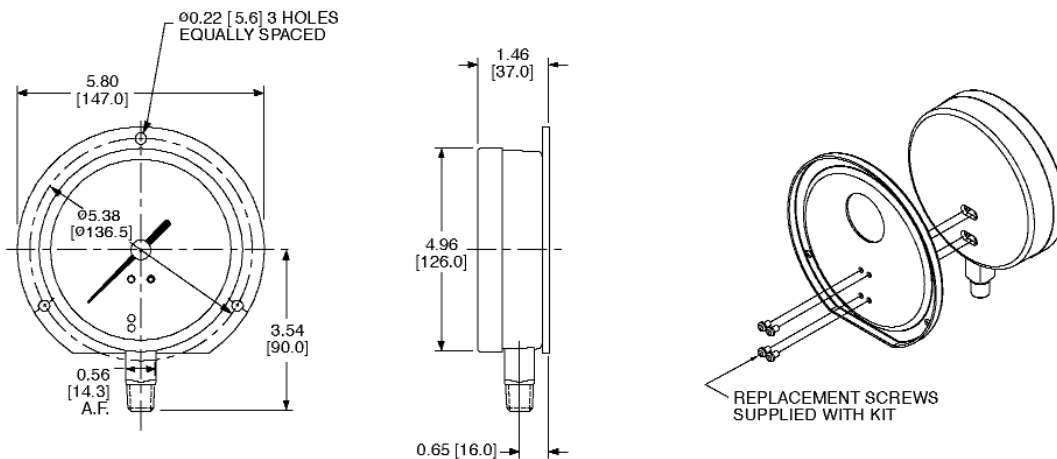

# Optional Case Styles

## 700 Series

All dimensions are nominal. Dimensions in [ ] are in millimeters.

**How to Order:** Specify the Optional Case Code at the end of the Instrument Ordering Code.

**Sample Order Number:** 700SS 40 04 B D 220 - FMB

Case Style - 700 Series	DIAL SIZE		
	2 1/2"	4"	6"
Surface Mounted Case with Back Flange, Lower Connection	N/A	SML	SML
Surface Mounted Case with Back Flange, Back Connection	SMB	SMB	SMB
Flush Mounted Case with Front Flange, Back Connection	FMB	FMB	FMB
Flush Mounted Case with Front Flange, Lower Connection	N/A	FML	FML
Panel Mounted Case with U-Clamp, Back Connection	UCB	UCB	UCB

N/A = Not available. Please order using the code listed.

### 2 1/2", 4" & 6" Surface Mount

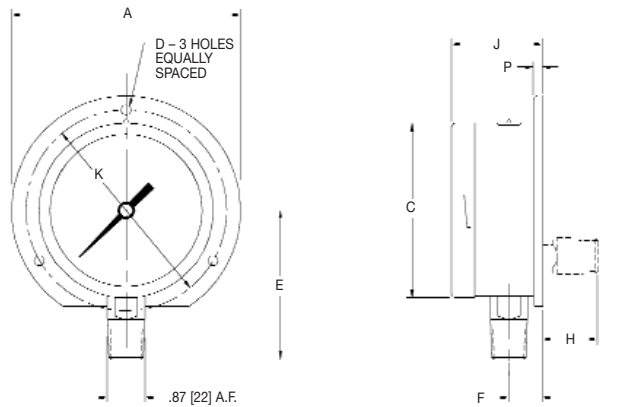

Dial Size	Material	A	C	D	E	F	G	H	J	K	P
2 1/2" [63]	Brass	3.35 [85]	2.52 [64]	0.14 [3.6]	2.22 [56.5]	0.57 [14.5]	0 [0]	0.98 [25]	1.56 [39.5]	2.95 [75]	0.22 [5.5]
	SS	3.35 [85]	2.52 [64]	0.14 [3.6]	2.22 [56.5]	0.57 [14.5]	0 [0]	0.98 [25]	1.56 [39.5]	2.95 [75]	0.22 [5.5]
4" [100]	Brass	5.20 [132]	3.98 [101]	0.19 [5]	3.39 [86]	0.75 [19]	1.04 [27]	1.32 [34]	2.07 [53]	4.57 [116]	0.22 [5.5]
	SS	5.20 [132]	3.98 [101]	0.19 [5]	3.39 [86]	0.75 [19]	1.36 [35]	1.26 [32]	2.07 [53]	4.57 [116]	0.22 [5.5]
6" [150]	Brass	7.72 [196]	6.34 [161]	0.23 [6]	4.57 [116]	0.81 [21]	1.04 [27]	1.32 [34]	2.09 [53]	7.01 [178]	0.24 [6]
	SS	7.72 [196]	6.34 [161]	0.23 [6]	4.57 [116]	0.81 [21]	1.36 [35]	1.26 [32]	2.09 [53]	7.01 [178]	0.24 [6]

### 2 1/2" Front Flange

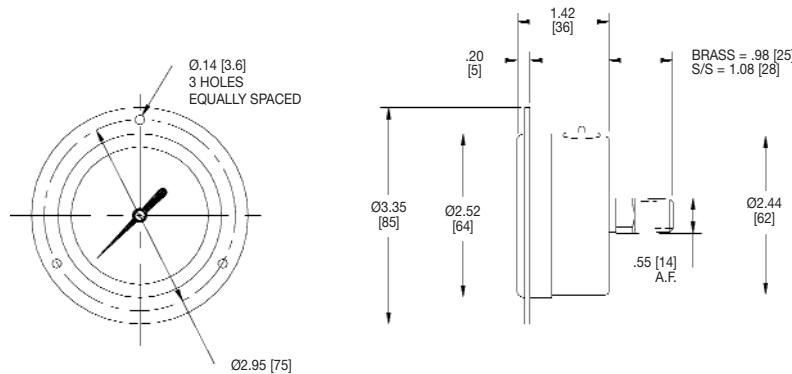

# Optional Case Styles

## 700 Series

All dimensions are nominal. Dimensions in [ ] are in millimeters.

OPTIONS & ACCESSORIES

### 4" & 6" Front Flange

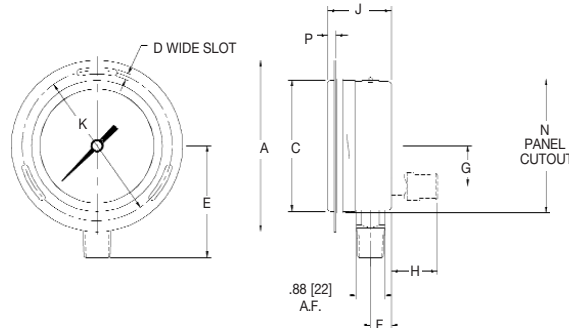

Dial Size	Material	A	C	D	E	F	G	H	J	K	N	P
4" [100]	Brass	5.20 [132]	3.98 [101]	0.19 [5]	3.39 [86]	0.63 [16]	1.04 [27]	1.44 [37]	1.93 [49]	4.57 [116]	4.13 [105]	0.24 [6]
	SS	5.20 [132]	3.98 [101]	0.19 [5]	3.39 [86]	0.63 [16]	1.36 [35]	1.38 [35]	1.93 [49]	4.57 [116]	4.13 [105]	0.24 [6]
6" [150]	Brass	7.72 [196]	6.34 [161]	0.23 [6]	4.57 [116]	0.69 [18]	1.04 [27]	1.44 [37]	1.97 [50]	7.01 [178]	6.50 [165]	0.24 [6]
	SS	7.72 [196]	6.34 [161]	0.23 [6]	4.57 [116]	0.69 [18]	1.36 [35]	1.38 [35]	1.97 [50]	7.01 [178]	6.50 [165]	0.24 [6]

### 2 1/2" U-Clamp

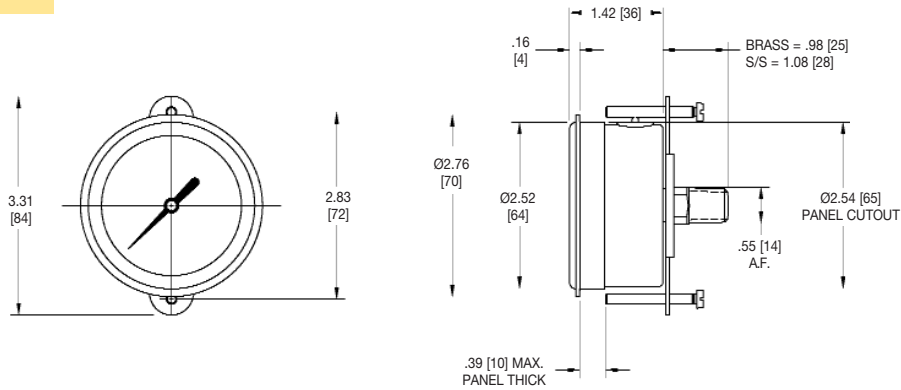

### 4" & 6" U-Clamp

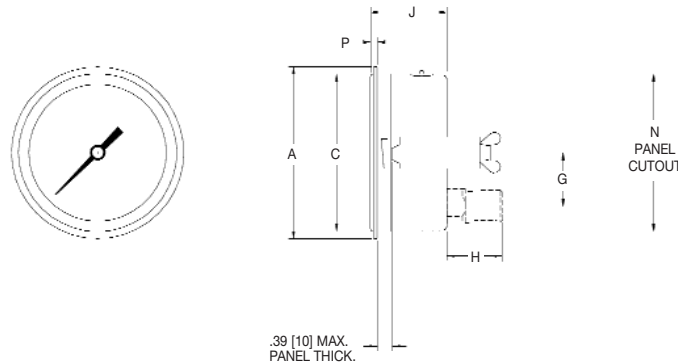

Dial Size	Material	A	C	G	H	J	N	P
4" [100]	Brass	4.33 [110]	3.98 [101]	1.04 [27]	1.44 [37]	1.93 [49]	4.02 [102]	0.18 [5]
	SS	4.33 [110]	3.98 [101]	1.36 [35]	1.38 [35]	1.93 [49]	4.02 [102]	0.18 [5]
6" [150]	Brass	6.69 [170]	6.34 [161]	1.04 [27]	1.44 [37]	1.97 [50]	6.39 [162]	0.24 [6]
	SS	6.69 [170]	6.34 [161]	1.36 [35]	1.38 [35]	1.97 [50]	6.39 [162]	0.24 [6]

# Optional Case Styles

## 760B, 765B & 766SS

All dimensions are nominal. Dimensions in [ ] are in millimeters.

**How to Order:** Specify the Optional Case Code at the end of the Instrument Ordering Code.

**Sample Order Number:** 766SS 60 02 L M 660 - SML

	760B	760B	765B/766SS	765B/766SS
<b>Optional Case Styles for 760B, 765B &amp; 766SS</b>	<b>2 1/2"</b>	<b>4"</b>	<b>4"</b>	<b>6"</b>
Surface Mounted Case with Back Flange, Lower Connection	N/A	N/A	SML	SML
Surface Mounted Case with Back Flange, Back Connection	N/A	N/A	SMB	SMB
Flush Mounted Case with Front Flange, Back Connection	FMB	FMB	FMB	FMB
Flush Mounted Case with Front Flange, Lower Connection	N/A	N/A	FML	FML
Panel Mounted Case with U-Clamp, Back Connection	UCB*	N/A	UCB	UCB

N/A = Not available. Please order using the code listed.  
\*Supplied with stainless steel case.

### 765B & 766SS 4" & 6" Surface Mount

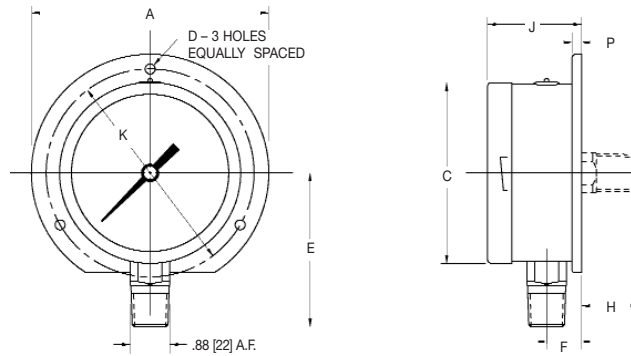

Dial Size	A	C	D	E	F	H	J	K	P
4" [100]	5.20 [132]	3.98 [101]	.19 [5]	3.43 [87]	.75 [19]	1.26 [32]	2.07 [53]	4.57 [116]	.22 [5.5]
6" [150]	7.72 [196]	6.34 [161]	.23 [6]	4.84 [123]	.81 [21]	1.26 [32]	2.09 [53]	7.01 [178]	.22 [5.5]

### 760B 2 1/2" Front Flange

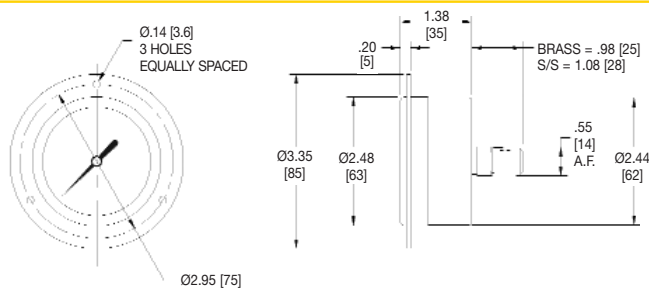

# Optional Case Styles

## 760B, 765B & 766SS

All dimensions are nominal. Dimensions in [ ] are in millimeters.

OPTIONS & ACCESSORIES

### 760B 4" Front Flange

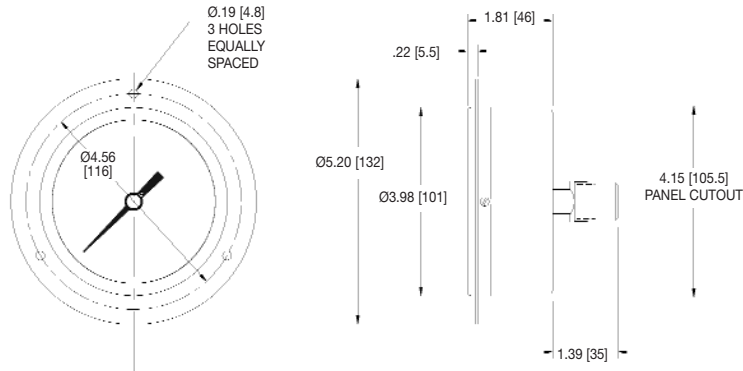

### 765B/766SS 4" & 6" Front Flange

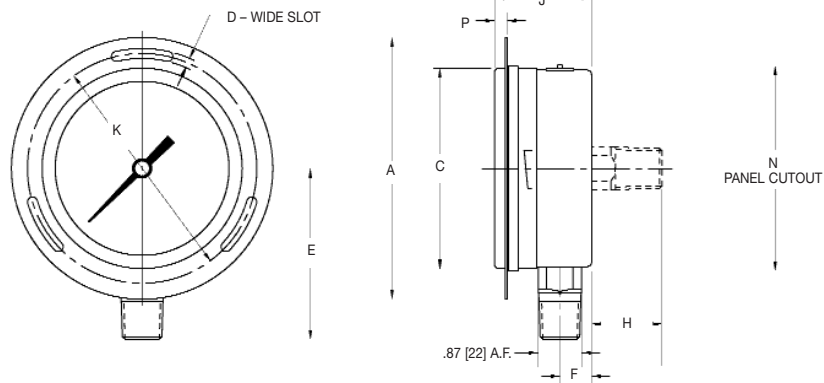

Dial Size	Material	A	C	D	E	F	H	J	K	N	P
4" [100]	Brass	5.20 [132]	3.98 [101]	.19 [5]	3.43 [87]	0.63 [16]	1.38 [35]	1.93 [49]	4.57 [116]	4.13 [105]	0.24 [6]
	SS	5.20 [132]	3.98 [101]	.19 [5]	3.43 [87]	0.63 [16]	1.38 [35]	1.93 [49]	4.57 [116]	4.13 [105]	0.24 [6]
6" [150]	Brass	7.72 [196]	6.34 [161]	.23 [6]	4.76 [121]	0.69 [18]	1.38 [35]	1.97 [50]	7.01 [178]	6.50 [165]	0.24 [6]
	SS	7.72 [196]	6.34 [161]	.23 [6]	4.84 [123]	0.69 [18]	1.38 [35]	1.97 [50]	7.01 [178]	6.50 [165]	0.24 [6]

### 765B/766SS 2 1/2" U-Clamp\*

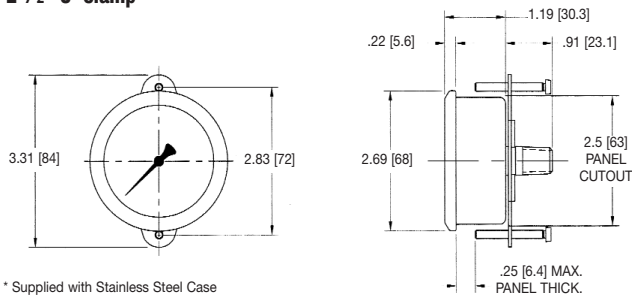

\* Supplied with Stainless Steel Case

### 765B/766SS 4" & 6" U-Clamp

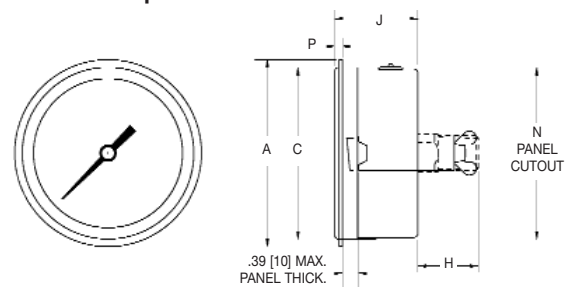

Dial Size	Material	A	C	H	J	N	P
4" [100]	Brass	4.33 [110]	3.98 [101]	1.44 [37]	1.93 [49]	4.02 [102]	0.18 [5]
	SS	4.33 [110]	3.98 [101]	1.38 [35]	1.93 [49]	4.02 [102]	0.18 [5]
6" [150]	Brass	6.69 [170]	6.34 [161]	1.44 [37]	1.97 [50]	6.39 [162]	0.24 [6]
	SS	6.69 [170]	6.34 [161]	1.38 [35]	1.97 [50]	6.39 [162]	0.24 [6]

# Optional Case Styles

## D80 Series

All dimensions are nominal. Dimensions in [ ] are in millimeters.

**How to Order:** Specify the Optional Case Code at the end of the Instrument Ordering Code.

**Sample Order Number:** *D82LFB 25 02 L A 160 - SML*

Case Style - D80 Series	Dial Size		
	2"	2 1/2"	4"
Surface Mounted, Back Flange Case for Lower Connection	N/A	SML	SML
* Panel Mounted, Front Flange Kit for Back Connection	198-0028	198-0025	198-0027
* Panel Mounted, Front Ring Kit for Back Connection	N/A	198-0024	N/A
Panel Mounted, U-Clamp Kit for Back Connection	198-0031	198-0026	UCB

\* Kit Only. Not Factory installed.

### 2 1/2" & 4" Surface Mount

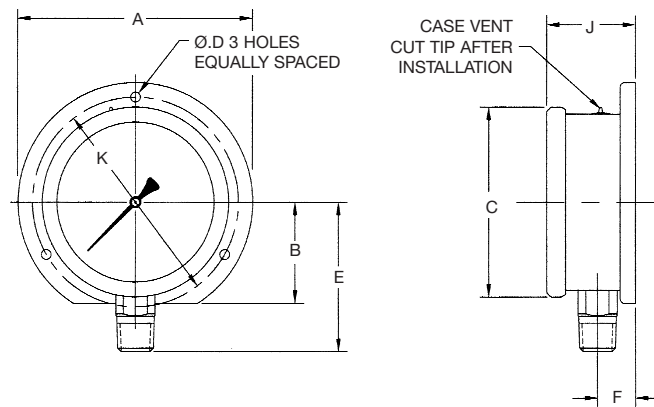

Dial Size	A	B	C	D	E	F	J	K
2 1/2"	3.35 [85]	1.43 [36.3]	2.68 [68]	0.14 [3.6]	2.23 [56.6]	0.52 [13.2]	1.38 [35.1]	2.95 [75]
4"	5.20 [132]	2.19 [55.6]	4.18 [106]	0.19 [4.8]	3.07 [78]	0.62 [15.7]	1.47 [37.3]	4.57 [116]

### 2", 2 1/2" & 4" Front Flange

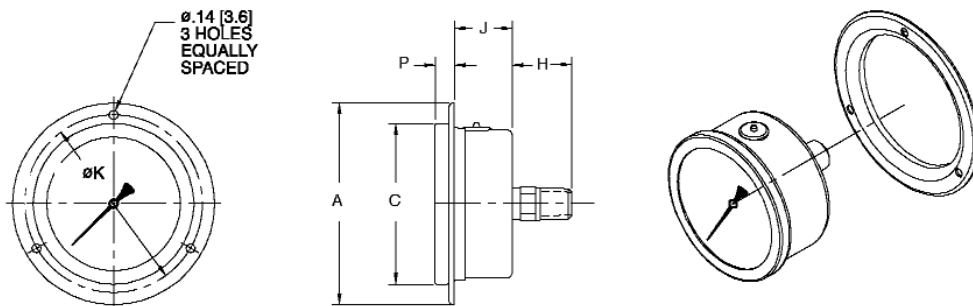

Dial Size	A	C	H	J	K	P
2"	3.03 [77]	2.09 [53]	0.99 [25]	0.94 [24]	2.65 [65]	0.32 [8]
2 1/2"	3.35 [85]	2.67 [68]	0.99 [25]	0.82 [21]	2.95 [75]	0.32 [8]
4"	5.20 [132]	4.17 [106]	0.99 [25]	0.91 [23]	4.56 [116]	0.42 [10]

# Optional Case Styles

## D80 Series

OPTIONS & ACCESSORIES

All dimensions are nominal. Dimensions in [ ] are in millimeters.

### 2 1/2" Front Ring

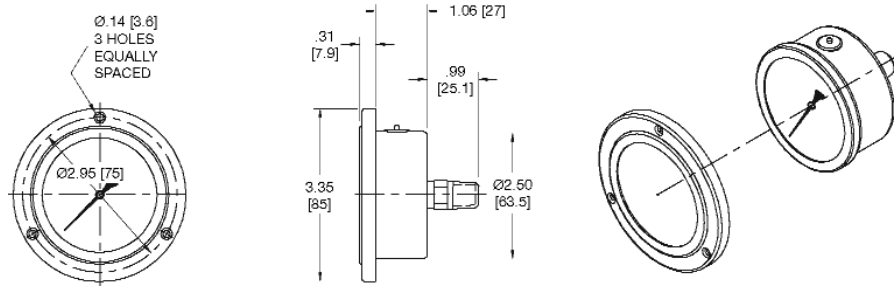

### 2", 2 1/2" & 4" U-Clamp

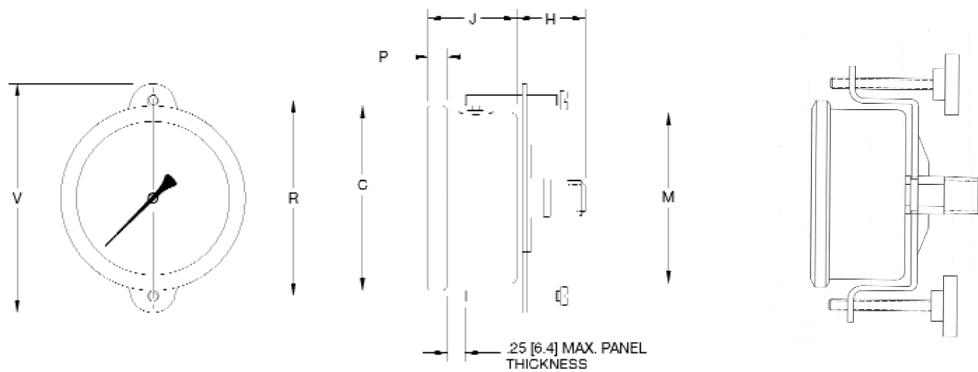

Dial Size	C	H	J	M	P	R	V
2"	2.09 [53]	.99 [25]	1.10 [28]	1.91 [48.5]	.18 [4.5]	2.28 [58]	2.76 [70]
2 1/2"	2.68 [68]	.99 [25]	1.20 [30.5]	2.44 [62]	.28 [7]	2.83 [72]	3.31 [84]
4"	4.17 [106]	.99 [25]	1.32 [33.5]	3.88 [98.6]	.28 [7]	4.33 [110]	4.80 [122]

# Optional Case Styles

## 800 Series

All dimensions are nominal. Dimensions in [ ] are in millimeters.

**How to Order:** Specify the Optional Case Code at the end of the Instrument Ordering Code.

**Sample Order Number:** 800B 15 01 B D 140 - UCB

Case Styles - 800 Series	Dial Size			
	1 1/2"	2"	2 1/2"	4"
Panel Mounted Case with Front Flange, Back Connection	FMB	FMB	FMB	FMB
Panel Mounted Case with U-Clamp, Back Connection	UCB	UCB	UCB	N/A

Please order using the code listed.

### Front Flange

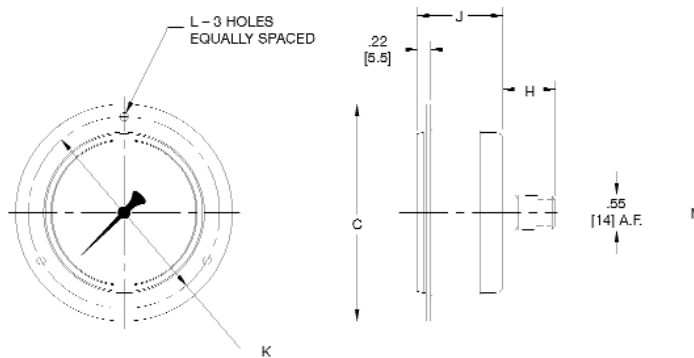

Dial Size	C	H	J	K	L	M
1 1/2"	2.40 [61]	0.73 [18.5]	0.98 [25]	1.97 [50]	.14 [3.5]	1.61 [41]
2"	2.80 [71]	0.83 [21]	1.02 [26]	2.36 [60]	.14 [3.5]	1.97 [50]
2 1/2"	3.35 [85]	0.83 [21]	1.06 [27]	2.95 [75]	.14 [3.5]	2.52 [64]
4"	5.20 [132]	0.98 [25]	1.26 [32]	4.57 [116]	.19 [4.8]	3.96 [100.5]

### 1 1/2", 2", 2 1/2" U-Clamp

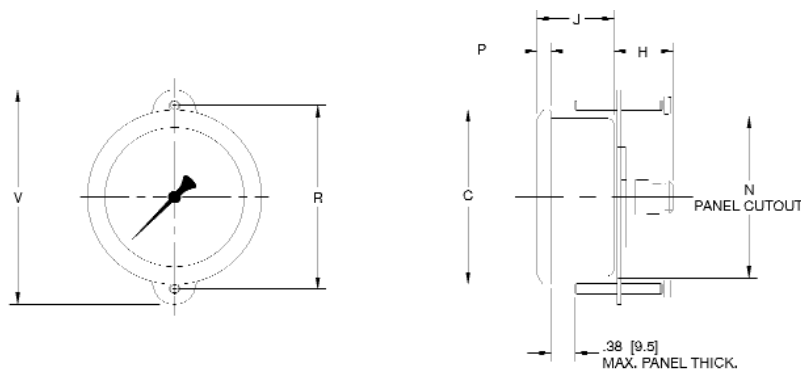

Dial Size	C	H	J	N	P	R	V
1 1/2"	1.73 [44]	1.08 [27.5]	1.12 [28.5]	1.57 [40]	0.24 [6]	1.97 [50]	2.44 [62]
2"	2.13 [54]	1.02 [26]	1.18 [30]	1.97 [50]	0.22 [5.5]	2.28 [58]	2.76 [70]
2 1/2"	2.68 [68]	1.02 [26]	1.18 [30]	2.48 [63]	0.22 [5.5]	2.83 [72]	3.31 [84]

# Optional Case Styles

## 800LF Series

All dimensions are nominal. Dimensions in [ ] are in millimeters.

**How to Order:** Specify the Optional Case Code at the end of the Instrument Ordering Code.

**Sample Order Number:** *800LFB 35 02 B A 030 - UCB*

Case Styles - 800LF Series	Dial Size	
	2 1/2"	3 1/2"
* Panel Mounted, Front Flange Kit for Back Connection	198-0020	N/A
* Surface Mounted, Back Flange Kit for Lower Connection	198-0022	N/A
* Panel Mounted, Front Ring Kit for Back Connection	198-0021	N/A
* Panel Mounted, U-Clamp Kit for Back Connection	198-0026	N/A
Panel Mounted Case with U-Clamp, Back Connection	N/A	UCB

**\* Kit Only. Not Factory installed.**

*Please order using the code listed.*

OPTIONS & ACCESSORIES

### 2 1/2" Front Flange

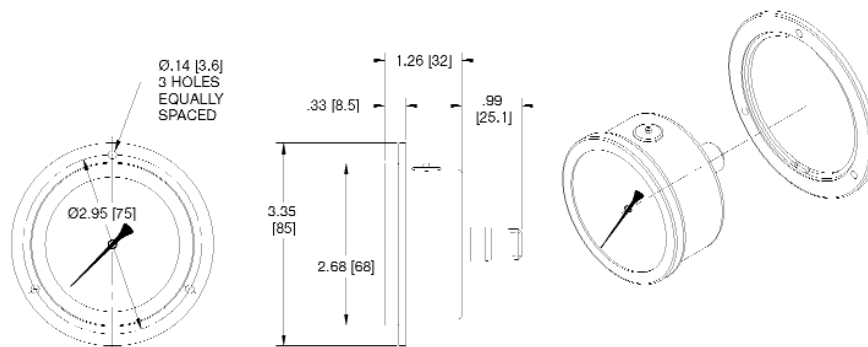

### 2 1/2" Back Flange

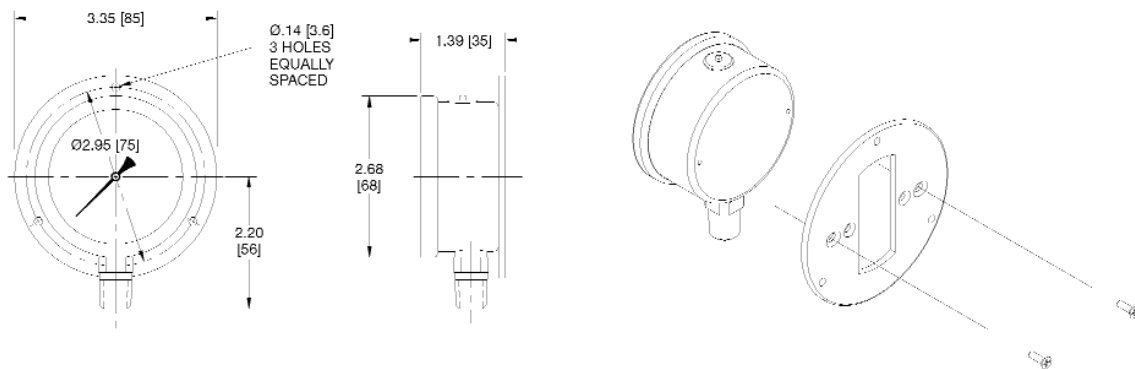

# Optional Case Styles

## 800LF Series (continued)

All dimensions are nominal. Dimensions in [ ] are in millimeters.

### 2 1/2" Front Ring

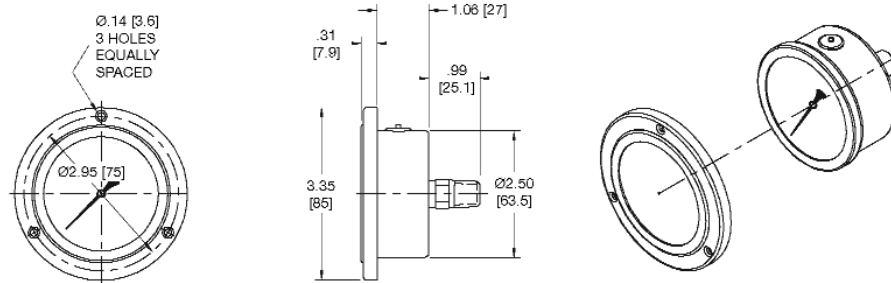

### 2 1/2" U-Clamp

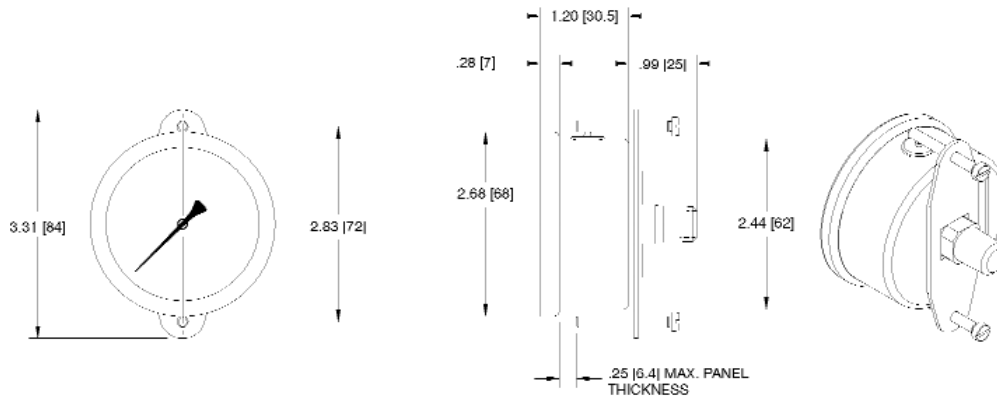

### 3 1/2" U-Clamp

